



Donaldson
FILTRATION SOLUTIONS

DATA SHEET

PowerCore® Dust Collectors Series CPC

POWERCORE DUST COLLECTOR WITH DUST CONTAINER

(without hopper) (CPC-6 illustrated).

Suitable for inside locations and outside when fitted with optional weather cowl.

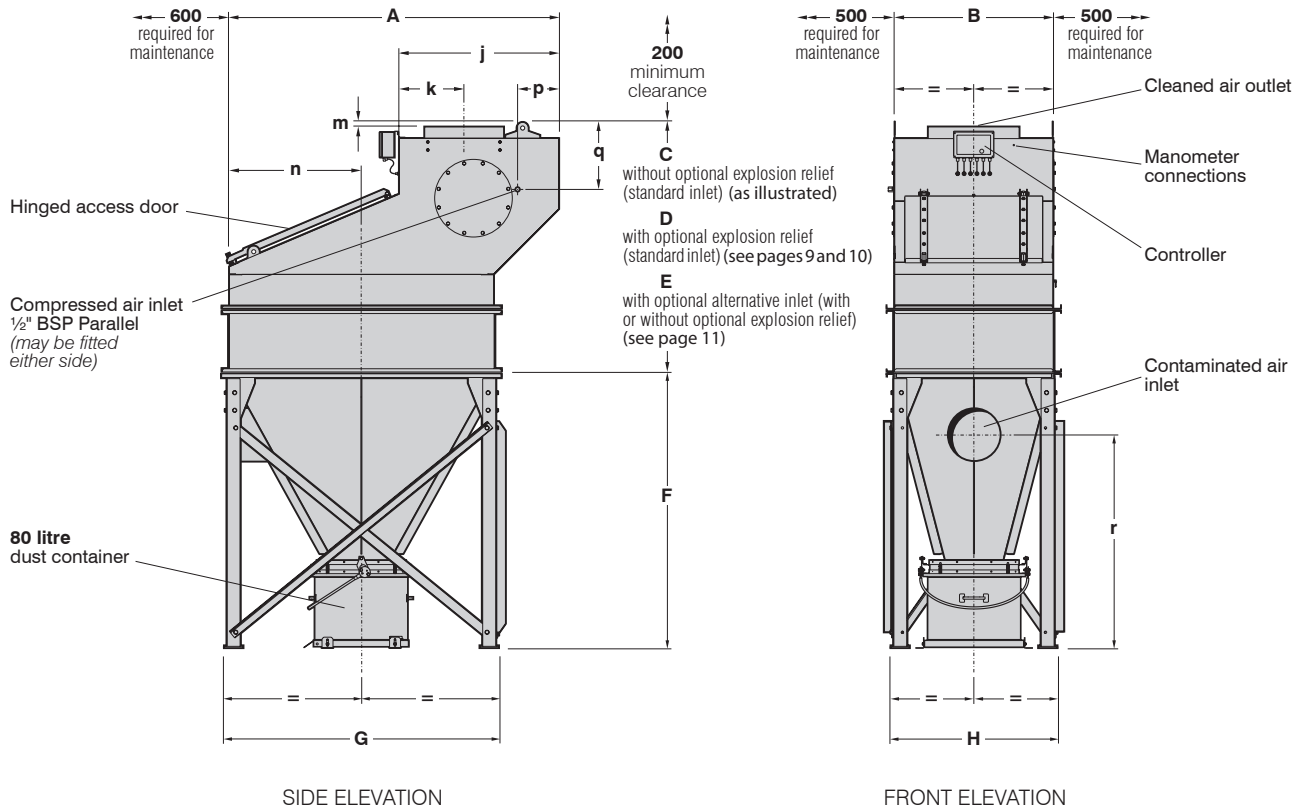

Type	Filtration area (Ultra-Web®)	Number of filter packs	Inlet spigot (inside dia.)	DIMENSIONS in mm														
				A	B	C	D	E	F	G	H	j	k	m	n	p	q	r
CPC-3	18.6 m ²	3	Ø200 mm	1247	915	1385	1385	1385	1017	959	981	850	345	25	444	200	270	848
CPC-4	24.8 m ²	4	Ø200 mm	1247	1169	1385	1385	1385	1237	959	1305	850	345	25	444	200	270	995
CPC-6	37.2 m ²	6	Ø300 mm	2060	995	1553	1769	1779	1657	1717	1057	1000	405	25	825	260	423	1275
CPC-8	49.6 m ²	8	Ø300 mm	2060	1169	1553	1769	1779	1657	1717	1231	1000	405	25	825	260	423	1275
CPC-12	74.4 m ²	12	Ø400 mm	2060	1728	1553	1919	1919	1720	1717	1790	1000	405	25	825	260	423	1317

POWERCORE DUST COLLECTOR WITH DUST CONTAINER

(with integral fan)

Suitable for inside and outside locations. (CPC-6F illustrated)

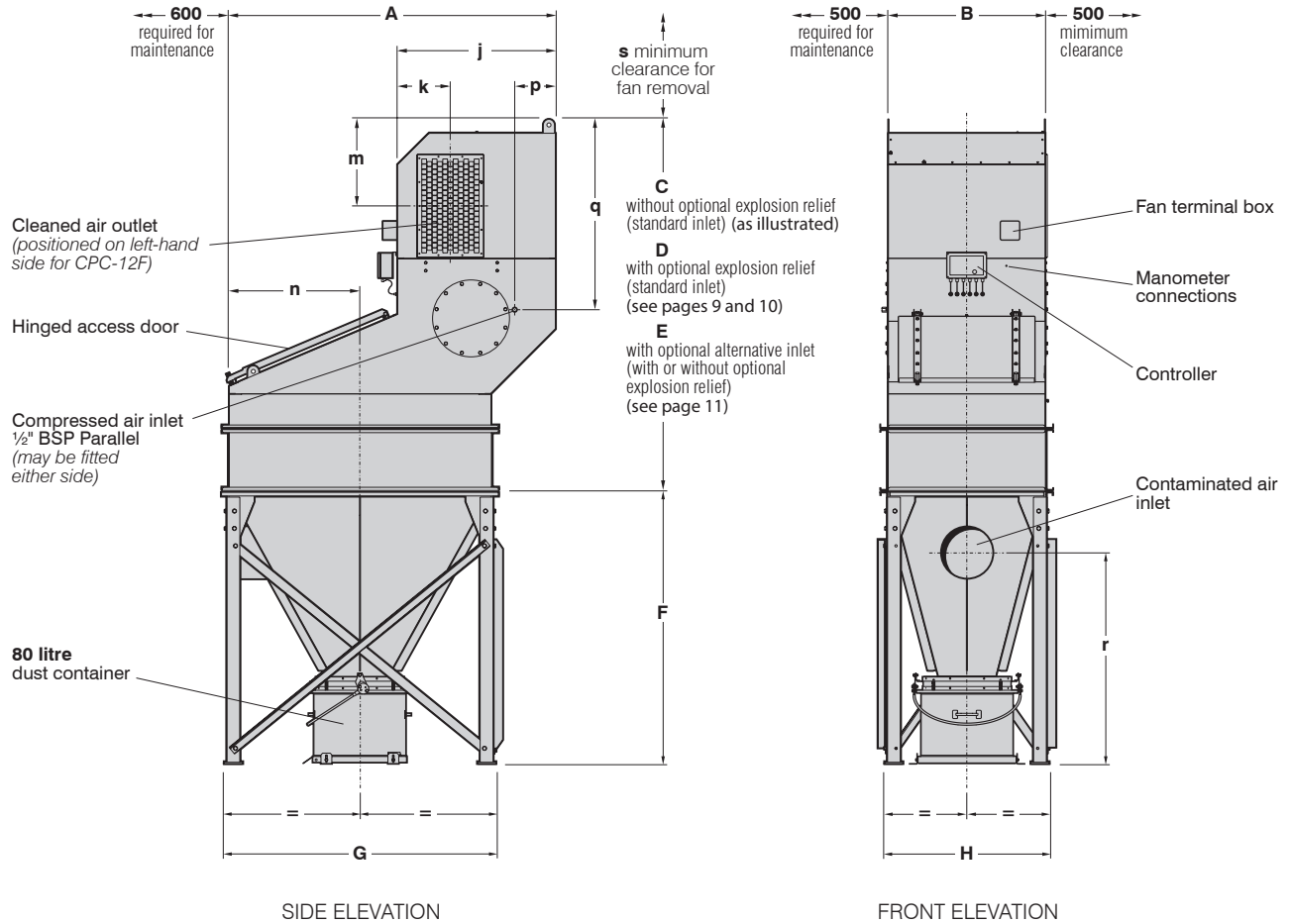

Type	Filtration area (Ultra-Web®)	No. of filter packs	Inlet spigot (inside dia.)	Fan	DIMENSIONS in mm															
					A	B	C	D	E	F	G	H	j	k	m	n	p	q	r	s
CPC-3F	18.6 m ²	3	Ø200 mm	K5																
				K7	1247	915	2108	2108	2108	1017	959	981	850	312	508	444	200	993	848	650
				SF40																
CPC-4F	24.8 m ²	4	Ø200 mm	K7																
				SF40	1247	1169	2163	2163	2163	1237	959	1305	850	312	563	444	200	1048	995	700
				K10																
CPC-6F	37.2 m ²	6	Ø300 mm	K10	2060		2331	2547	2557				1000	335	548		260	1201		700
				K11	2060	995	2331	2547	2557	1657	1717	1057	1000	335	548	825	260	1201	1275	700
				K15	2180		2641	2857	2867					1240	425	733		380	1511	
CPC-8F	49.6 m ²	8	Ø300 mm	K11	2060		2331	2547	2557				1000	335	548		260	1201		700
				K15	2180	1169	2641	2857	2867	1657	1717	1231	1000	335	548	825	260	1201	1275	700
				K15	2180		2641	2857	2867					1240	425	733		380	1511	
CPC-12F	74.4 m ²	12	Ø400 mm	K15 ART 562	2060	1728	2553	2919	2919	1720	1717	1790	1000	500	720	825	260	1423	1317	1100

ALTERNATIVE HOPPER AND SUPPORT ARRANGEMENTS

(CPC-6 illustrated)

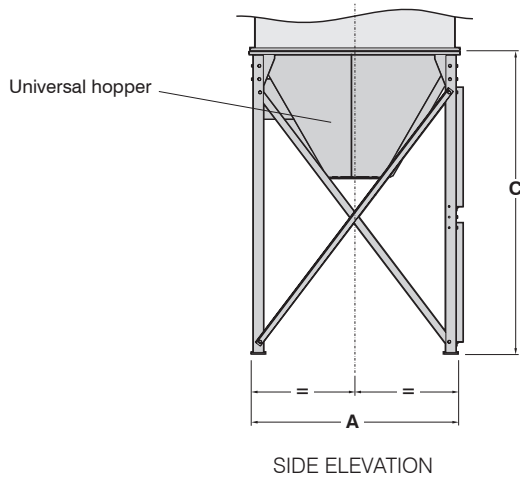

SIDE ELEVATION

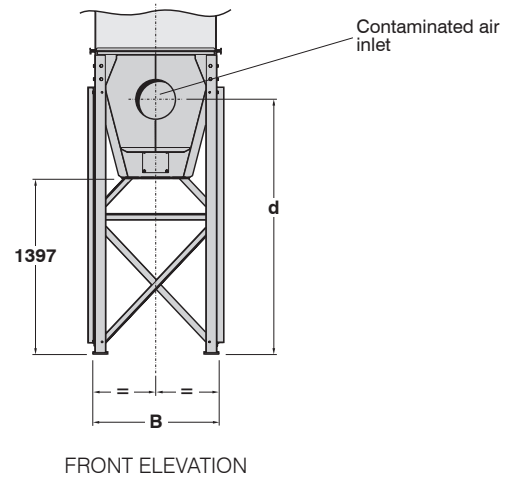

FRONT ELEVATION

Universal hopper

Type	A	B	C	d
CPC-3U and CPC-3FU	959 mm	981 mm	1801 mm	1666 mm
CPC-4U and CPC-4FU	959 mm	1305 mm	2021 mm	1813 mm
CPC-6U and CPC-6FU	1717 mm	1057 mm	2442 mm	2094 mm
CPC-8U and CPC-8FU	1717 mm	1231 mm	2442 mm	2094 mm
CPC-12U and CPC-12FU	1717 mm	1790 mm	2505 mm	2136 mm

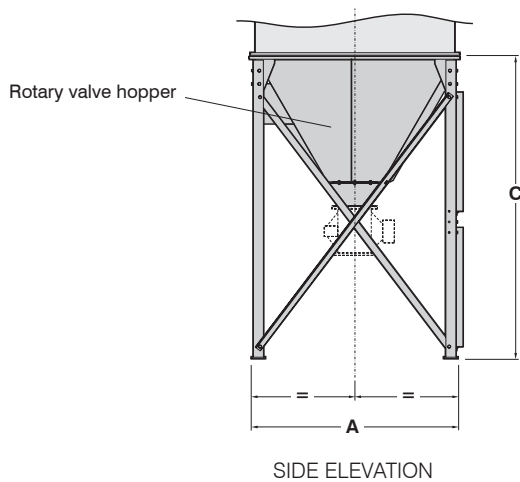

SIDE ELEVATION

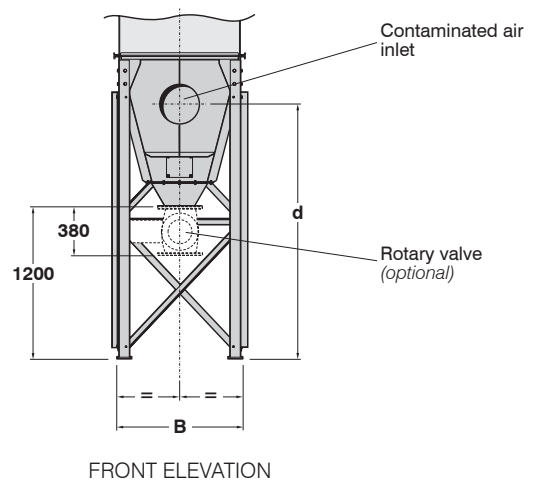

FRONT ELEVATION

Rotary valve hopper

Type	A	B	C	d
CPC-3R and CPC-3FR	959 mm	981 mm	1801 mm	1666 mm
CPC-4R and CPC-4FR	959 mm	1305 mm	2021 mm	1813 mm
CPC-6R and CPC-6FR	1717 mm	1057 mm	2442 mm	2094 mm
CPC-8R and CPC-8FR	1717 mm	1231 mm	2442 mm	2094 mm
CPC-12R and CPC-12FR	1717 mm	1790 mm	2505 mm	2136 mm

FAN SELECTION

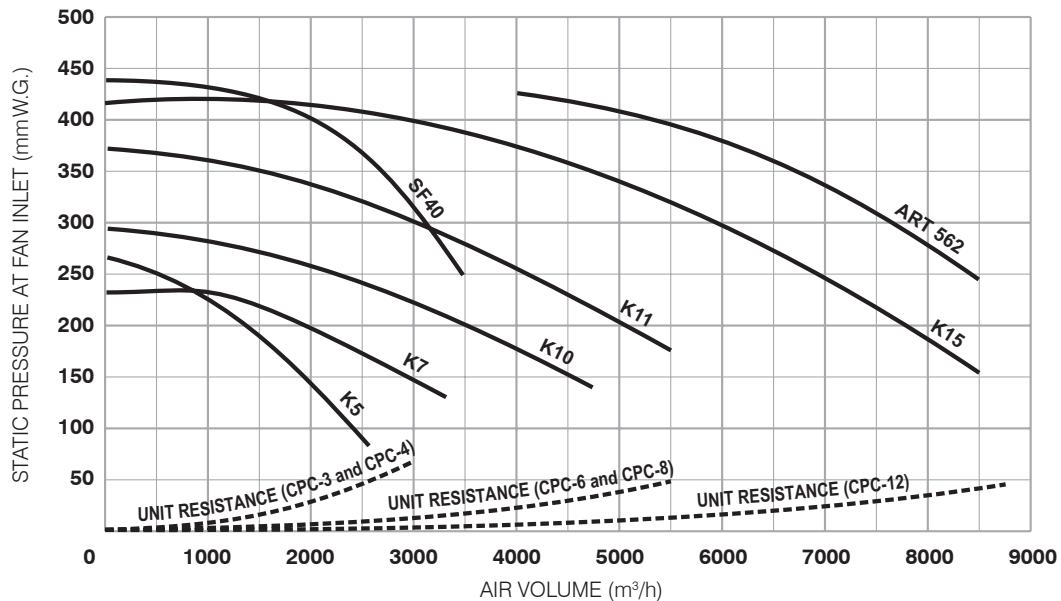

Unit performance curves

Estimated data

These curves indicate static pressure available at fan inlet for a given volume when fitted inside a PowerCore CPC dust collector.

To select the most suitable fan for a given application:

- 1 Determine the air volume, in m³/h, needed to entrain the dust.
- 2 Read off the unit resistance, in mm W.G., at air volume required.
- 3 Assess pressure drop over dust collector, prior to cleaning, usually 100 mm W.G.
- 4 Estimate pressure drop through connected system – i.e. between point of entrainment and collector inlet.
- 5 The sum of **2**, **3** and **4** = W.G. required.
- 6 Consult graph for fan performance available.

NOISE LEVELS

Machinery noise levels are an important consideration in the design and selection of new equipment. Several EC Directives and National Laws/Regulations adopting these directives make reference to airborne noise emissions. Actions that employers are required to comply with if employees are subjected to a daily personal noise exposure Lep,d of 80 dB(A) or more are also specified.

All readings were taken in normal industrial areas, i.e. semi-reverberant surroundings, with local equipment silent. Measurements were taken at maximum air flow conditions at 1.0 metre radius from the equipment housing and 1.6 metres above base level, using a precision sound level meter and octave filter.

K5	K7	SF 40	K10	K11	K15	ART 562
(2.2 kW)	(3.0 kW)	(4.0 kW)	(5.5 kW)	(7.5 kW)	(11.0 kW)	(11.0 kW)
75 dB(A)	77 dB(A)	75 dB(A)	75 dB(A)	79 dB(A)	79 dB(A)	79 dB(A)

Noise levels of installed equipment may vary due to site conditions. Estimated data.

COMPRESSED AIR REQUIREMENTS

Type	Working compressed air pressure ^a		Atmospheric air volume – F.A.D. ^b at 12 s intervals ^c		Pulse duration
	bar	psig	m ³ /h	cfm	
CPC-3	6.2	90	16	9.4	100ms
CPC-4	6.2	90	20	11.8*	100ms
CPC-6	6.2	90	16	9.4	100ms
CPC-8	6.2	90	20	11.8*	100ms
CPC-12	6.2	90	25	14.7	100ms

^aNormal operating pressure.

^bRecommended atmospheric air volume of clean, dry compressed air.

^cRecommended initial settings; these may be varied with experience.

* Estimated data.

NET WEIGHTS

Collector with dust container			Collector with universal hopper			Collector with rotary valve hopper		
Type	Fan type	Net weight (approx.)	Type	Fan type	Net weight (approx.)	Type	Fan type	Net weight (approx.)
CPC-3	–	443 kg	CPC-3U	–	458 kg	CPC-3R	–	474 kg
	K5	603 kg		K5	619 kg		K5	634 kg
CPC-3F	K7	628 kg	CPC-3FU	K7	644 kg	CPC-3FR	K7	659 kg
	SF40	679 kg		SF40	695 kg		SF40	710 kg
	K10	658 kg		K10	674 kg		K10	689 kg
CPC-4	–	531 kg	CPC-4U	–	547 kg	CPC-4R	–	563 kg
	K7	737 kg		K7	753 kg		K7	769 kg
CPC-4F	SF40	788 kg	CPC-4FU	SF40	804 kg	CPC-4FR	SF40	820 kg
	K10	767 kg		K10	783 kg		K10	799 kg
CPC-6	–	784 kg	CPC-6U	–	811 kg	CPC-6R	–	826 kg
	K10	994 kg		K10	1020 kg		K10	1036 kg
CPC-6F	K11	1061 kg	CPC-6FU	K11	1087 kg	CPC-6FR	K11	1103 kg
	K15	1186 kg		K15	1213 kg		K15	1228 kg
CPC-8	–	855 kg	CPC-8U	–	872 kg	CPC-8R	–	887 kg
CPC-8F	K11	1138 kg	CPC-8FU	K11	1155 kg	CPC-8FR	K11	1171 kg
	K15	1271 kg		K15	1289 kg		K15	1305 kg
CPC-12	–	1116 kg	CPC-12U	–	1132 kg	CPC-12R	–	1148 kg
CPC-12F	K15	1559 kg	CPC-12FU	K15	1576 kg	CPC-12FR	K15	1591 kg
	ART 562	1564 kg		ART 562	1581 kg		ART 562	1596 kg

All weights shown indicate heaviest configuration

FOUNDATION DETAILS

(CPC-12 illustrated)

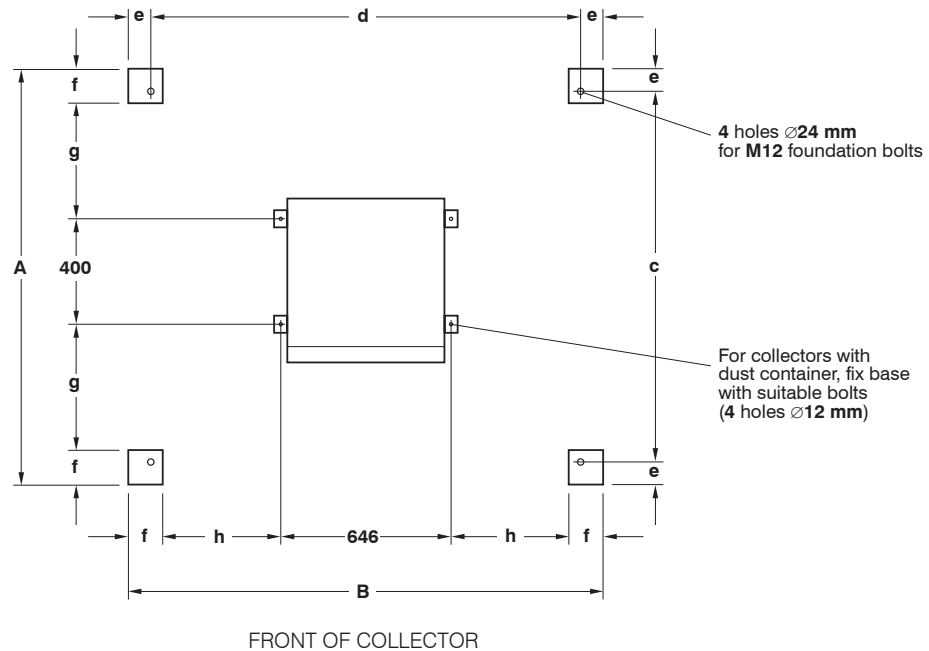

Type	A	B	c	d	e	f	g	h
CPC-3	959 mm	981 mm	819 mm	841 mm	70 mm	110 mm	169.5 mm	57.5 mm
CPC-4	959 mm	1305 mm	819 mm	1165 mm	70 mm	110 mm	169.5 mm	219.5 mm
CPC-6	1717 mm	1057 mm	1547 mm	887 mm	85 mm	130 mm	528.5 mm	75.5 mm
CPC-8	1717 mm	1231 mm	1547 mm	1061 mm	85 mm	130 mm	528.5 mm	162.5 mm
CPC-12	1717 mm	1790 mm	1547 mm	1620 mm	85 mm	130 mm	528.5 mm	442 mm

DESIGN LIMITS

(standard equipment)

Temperature range: -10° to +60°C

Pressure limits: Collectors without fan: -500 mmW.G. (For positive pressures please refer to Donaldson)
Collectors with fan: as fan performance curves from shut-off to operating pressure

Dimension tolerances: ±5 mm on main dimensions; ±2 mm on detail dimensions

Paint finish: Quick air drying RAL 5019 (blue), spatter finish, semi-gloss

Equipment is available suitable for use in a potentially explosive atmosphere (Directive 94/9/EC) satisfying the requirements for group II category 2G or 2D and 3G or 3D T135°C

CLEANED AIR OUTLET DETAILS FOR COLLECTORS WITH FAN

(outlet grille removed)

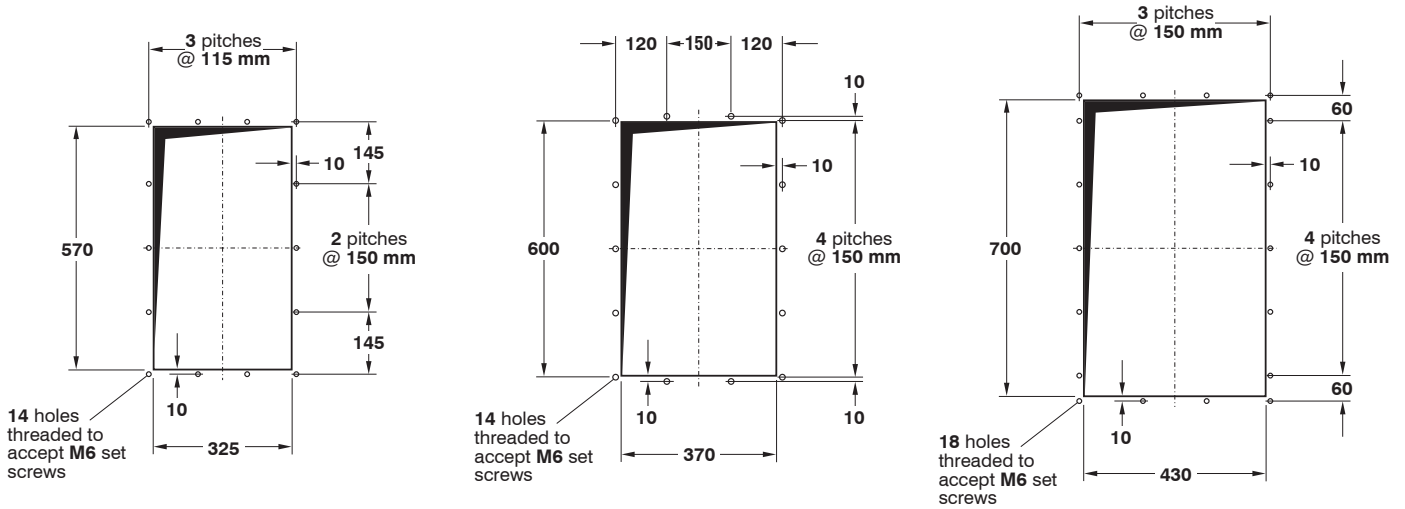

CPC-3F and CPC-4F

CPC-6F and CPC-8F

CPC-6F K15, CPC-8F K15 and CPC-12F

CLEANED AIR OUTLET DETAILS FOR COLLECTORS WITHOUT FAN

DIN 24154/2

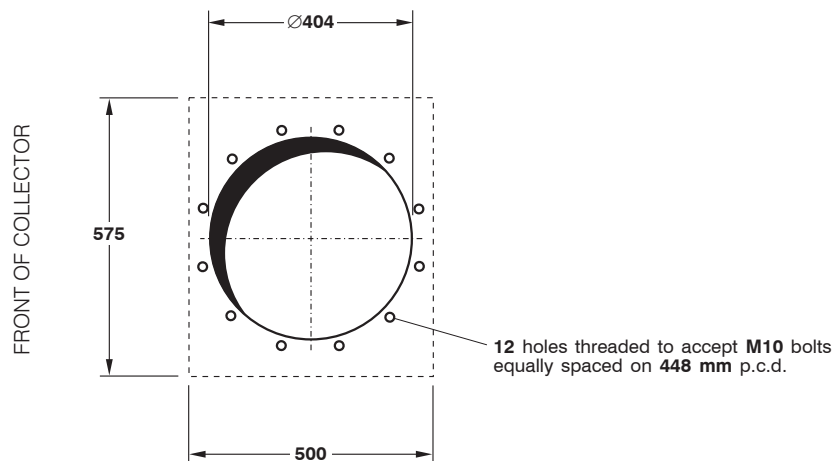

UNIVERSAL HOPPER OUTLET FLANGE DETAILS

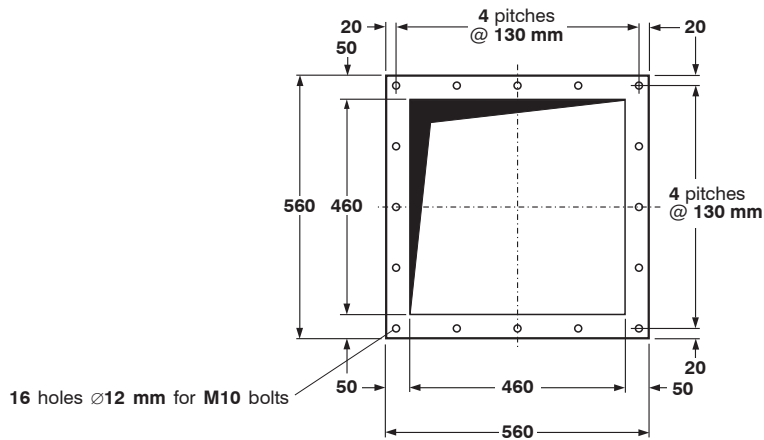

ROTARY VALVE HOPPER OUTLET FLANGE DETAILS

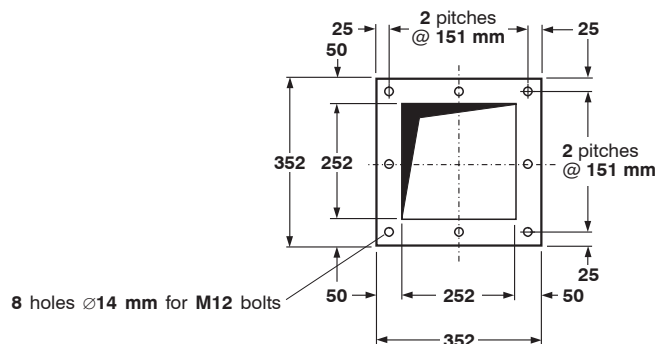

ROTARY VALVE HOPPER OUTLET FLANGE DETAILS

(for rotary valve supplied by Donaldson)

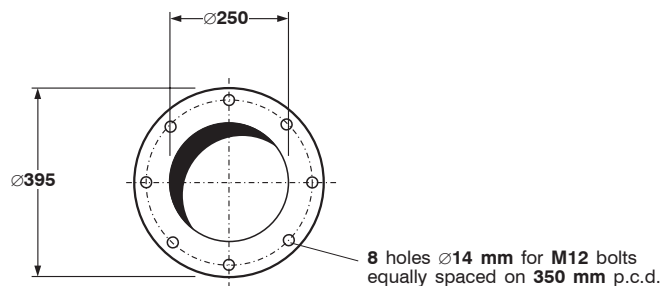

OPTIONAL EXPLOSION RELIEF (CPC-3, -4, -6 AND -8)

(showing flange mounting details)

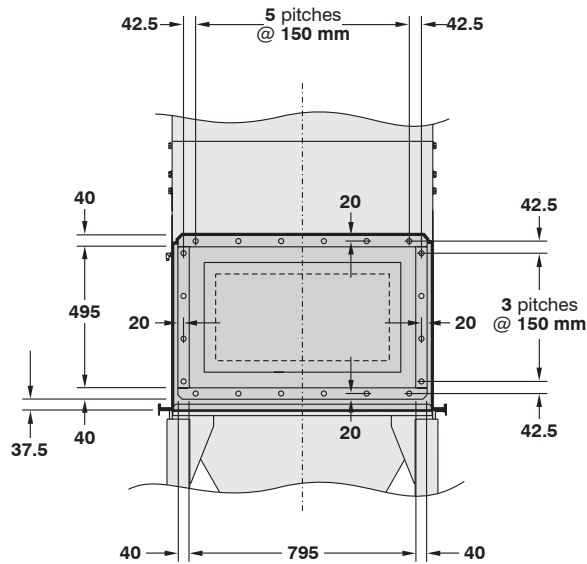

REAR ELEVATION

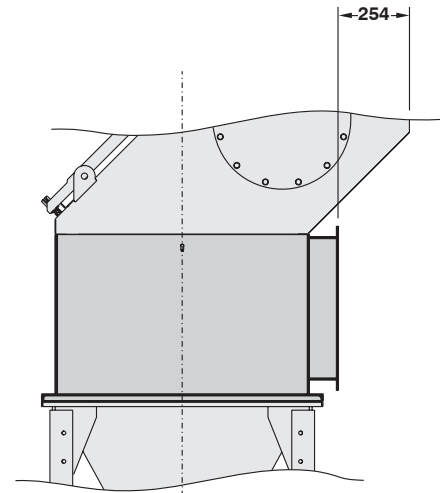

SIDE ELEVATION

CPC-3 and CPC-4

All holes \varnothing 12 mm for M10 bolts.

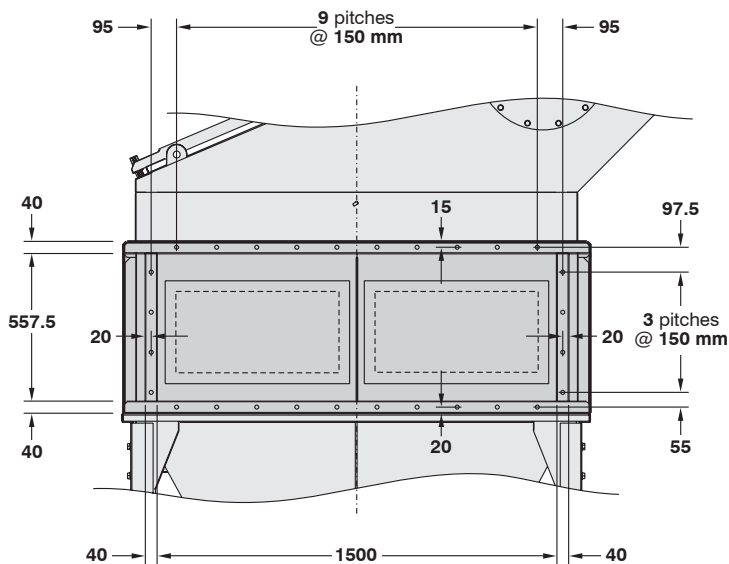

SIDE ELEVATION

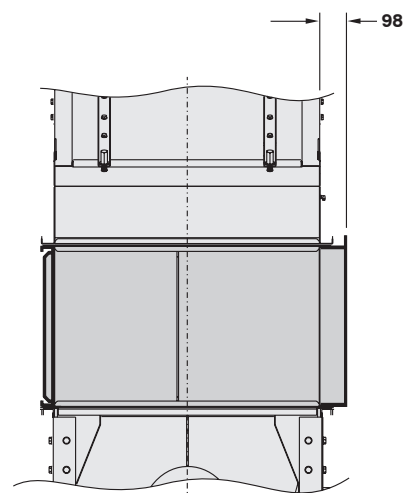

FRONT ELEVATION

CPC-6 and CPC-8

(Explosion relief may be fitted either side)

Top and vertical flange holes \varnothing 10 mm for M8 bolts. Bottom flange holes threaded to accept M8 bolts.

OPTIONAL EXPLOSION RELIEF (CPC-12)

(showing flange mounting details)

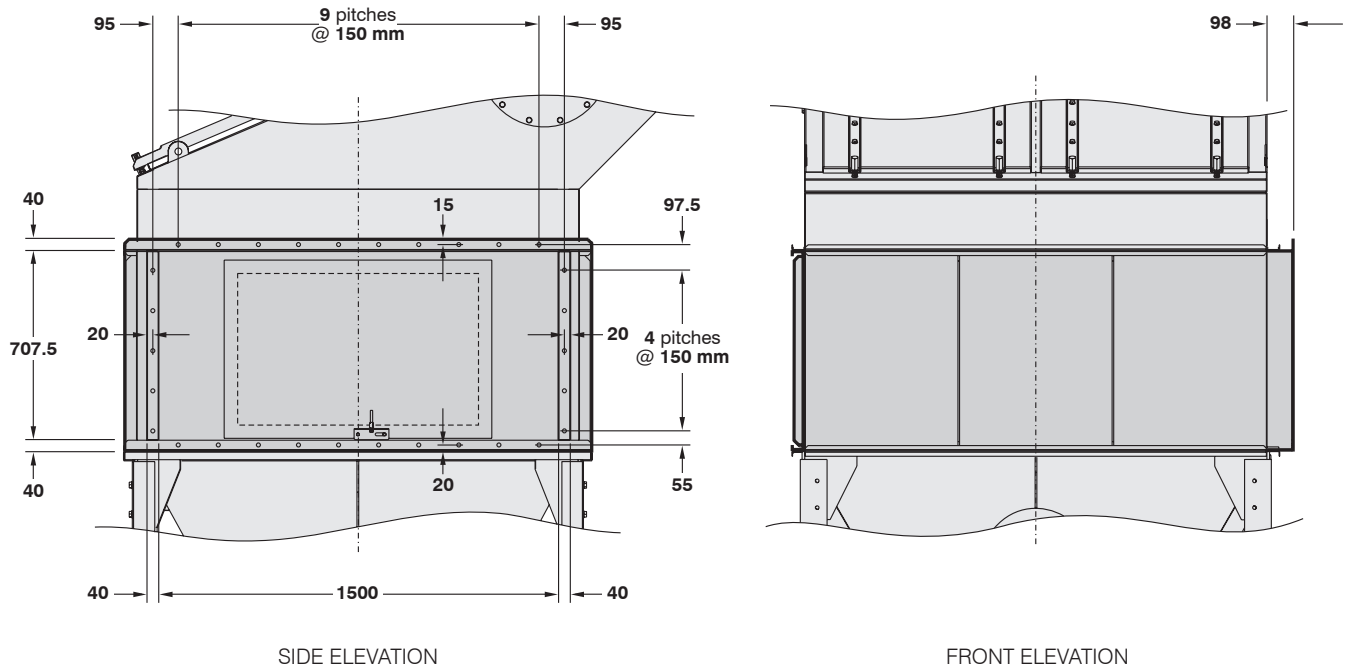

CPC-12

(Explosion relief may be fitted either side)

Top and vertical flange holes $\varnothing 10$ mm for M8 bolts. Bottom flange holes threaded to accept M8 bolts.

OPTIONAL POWER BOX

(CPC-6 illustrated)

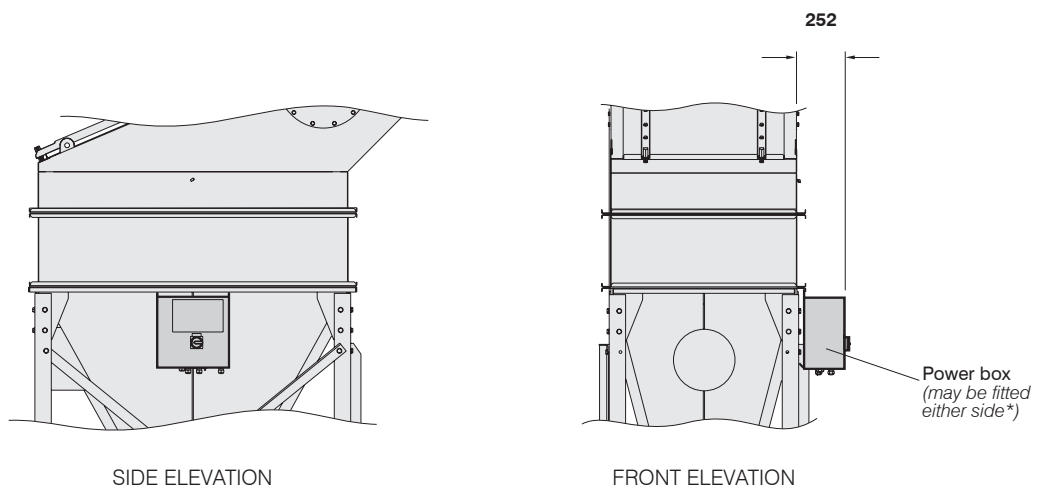

* The Power box must be fitted on the opposite side to the explosion panels on CPC-6, CPC-8 and CPC-12 collectors fitted with explosion relief.

OPTIONAL ALTERNATIVE CONTAMINATED AIR INLET ARRANGEMENT

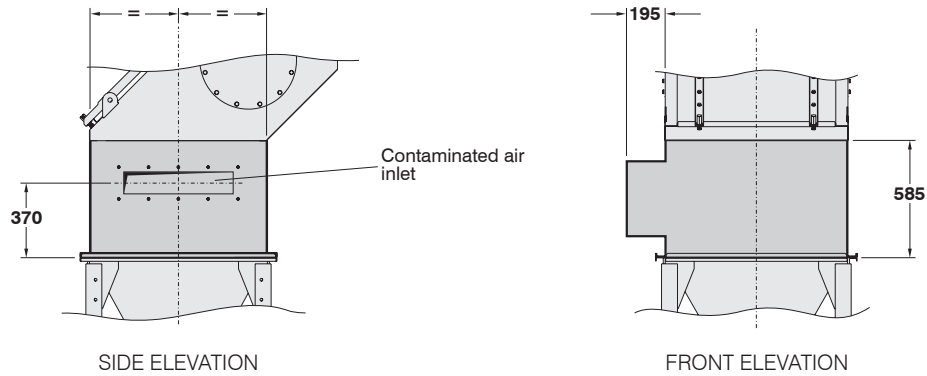

CPC-3 and CPC-4
(CPC-3 illustrated)

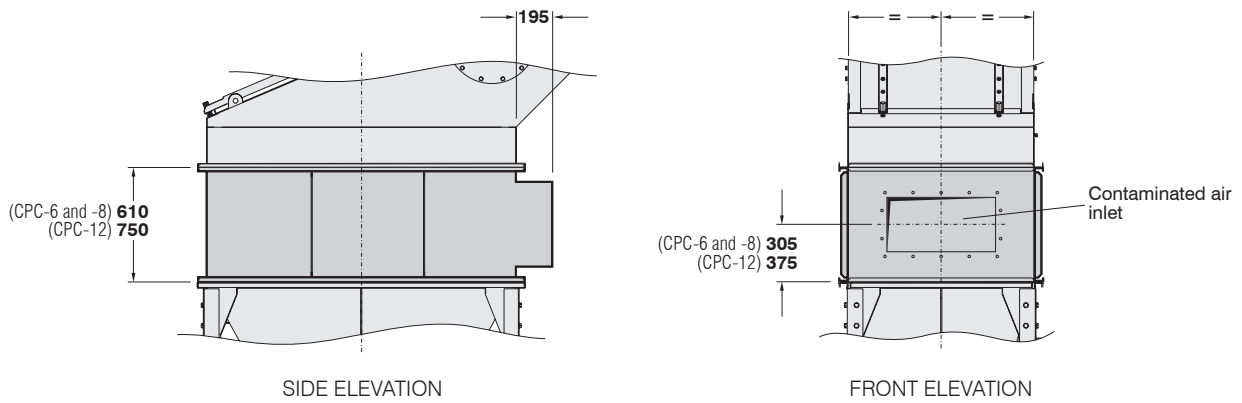

CPC-6, CPC-8 and CPC-12
(CPC-6 illustrated)

OPTIONAL WEATHER COWL

(CPC-6 illustrated)

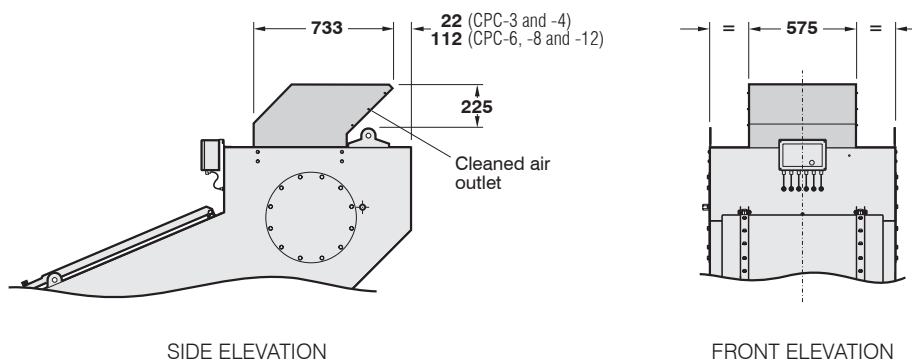

CONTAMINATED AIR INLET DETAILS FOR COLLECTORS WITH OPTIONAL ALTERNATIVE INLET ARRANGEMENT

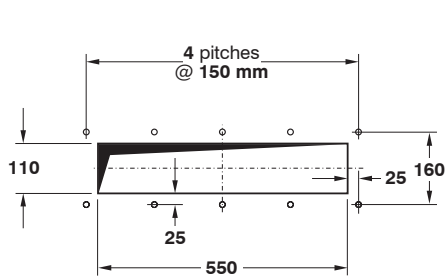

CPC-3 and CPC-4

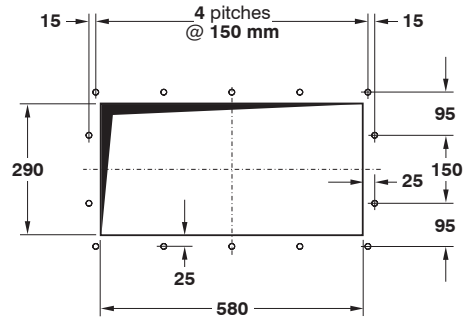

CPC-6

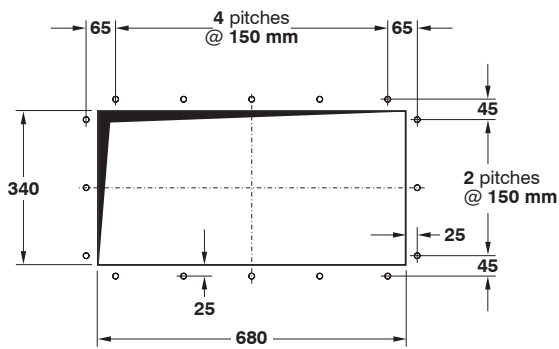

CPC-8

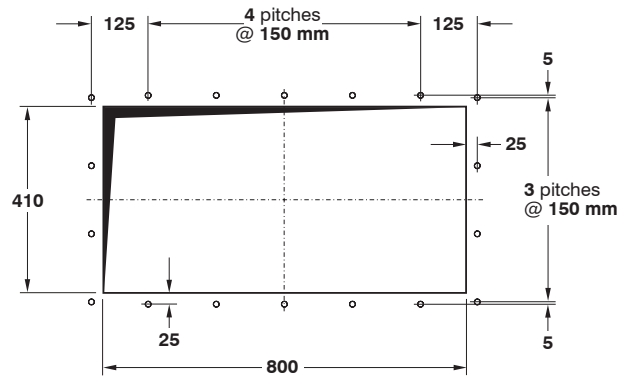

CPC-12

ELECTRICAL REQUIREMENTS

See Controller datasheet.

- Africa** Donaldson Europe B.V.B.A.
Industrial Filtration Solutions
Research Parc Bldg No. 1303
Interleuvenlaan, 1
B-3001 Leuven
Belgium
IAF-africa@donaldson.com +32 16 38 39 70
- Austria** Donaldson Filtration Österreich GmbH
Gutheil-Schoder Gasse 8-12
A-1100 Wien
Österreich
IAF-at@donaldson.com +43 16 16 52 91
- Belgium** Donaldson Europe B.V.B.A.
Industrial Filtration Solutions
Research Parc Bldg No. 1303
Interleuvenlaan, 1
B-3001 Leuven
België
IAF-be@donaldson.com +32 16 38 39 70
- Czech Republic** Donaldson Filtration CR - koncern s.r.o.
Konevova 139
CZ-130 83 Praha 3
Ceská republika
IAF-cz@donaldson.com +420 2 67 108 242
- Denmark** Donaldson Scandinavia ApS
Lyngsø Allé 3A
DK - 2970 Hørsholm
Danmark
IAF-dk@donaldson.com +45 45 57 00 77
- Finland** Donaldson Scandinavia ApS
Lyngsø Allé 3A
DK - 2970 Hørsholm
Danmark
IAF-fi@donaldson.com +45 45 57 00 77
- France** Donaldson France s.a.s.
33 Rue des Vanesses
Zac Paris Nord II B.P. 51292 Villepinte
F-95958 Roissy
Charles de Gaulle Cedex
France
IAF-fr@donaldson.com +33 1 49 38 99 30
- Germany** Industrial Filtration Solutions
Industriestraße 11
D-48249 Dülmen
Deutschland
IAF-de@donaldson.com + 49 2594 781-41
- Hungary** Donaldson Filtration Magyarország Kft.
Záhony u. 7.
H-1031 Budapest
Magyarország
IAF-hu@donaldson.com +36 1 453 28 65/66
- Ireland** Donaldson Filtration (GB) Ltd.
Suite 31, The Hyde Building The Park
Carrickmines, Dublin 18
Ireland
IAF-ie@donaldson.com +353 1 525 22 49
- Italy** Donaldson Italia S.r.l.
Via Cesare Pavese, 5/7
20090 Opera (Milan)
Italia
IAF-it@donaldson.com +39 0 25 30 05 21
- Middle East** Donaldson Europe B.V.B.A.
Office 1905
Jebel Ali Free Zone
Dubai
United Arab Emirates
IAF-middle-east@donaldson.com +971 4 885 5311
- Netherlands** Donaldson Nederland B.V.
Transistorstraat 44 III
NL-1322 CG Almere
Nederland
IAF-nl@donaldson.com +31 36 548 08 40
- Norway** Donaldson Filtration Norway AS
Postboks 196
N-1501 Moss
Norge
IAF-no@donaldson.com +47 69 21 53 00
- Poland** Donaldson Polska Sp.zo. o.
ul. Sienna 64
PL-00-825 Warszawa
Polska
IAF-pl@donaldson.com +48 22 517 15 00
- Russia** Представительство АООО Donaldson Nederland B.V.
Centr Meždunarodnoj Torgovii
Ofis 1004V, Krasnopresnenskaja nab.12
123610 Moskva
Russia
IAF-ru@donaldson.com +7 499 136 00 13
- Slovakia** Donaldson Filtration Slovensko s.r.o.
Púchovská 8
SK-83106 Bratislava 35
Slovensko
IAF-sk@donaldson.com +421 2 44872619
- Spain** Donaldson Ibérica, Soluciones en Filtración, S.L.
Colom, 391 - 3ªA
E-08223 Terrassa
España
IAF-es@donaldson.com +34 93 784 38 34
- Sweden** Donaldson Scandinavia
Industrigatan 68
S-261 35 Landskrona
Sverige
IAF-se@donaldson.com +46 418 457 550
- Switzerland** Donaldson Schweiz GmbH
Bruggacherstrasse 18
CH-8117 Fällanden
Schweiz
IAF-ch@donaldson.com +41 (0)44 302 07 15
- Turkey** Donaldson Filtre Sist. Tic. Ltd. Sti.
Barbaros Mahallesi Palladium Tower No:2 Kat:10
34746 Ataşehir / Istanbul
Türkiye
IAF-tr@donaldson.com +90 216 687 03 26
- United Kingdom** Donaldson Filtration (GB) Ltd.
Humberstone Lane Thurmaston
Leicester LE4 8HP
United Kingdom
IAF-uk@donaldson.com +44 116 269 6161
- Other countries** Donaldson Filtration (GB) Ltd.
Humberstone Lane Thurmaston
Leicester LE4 8HP
United Kingdom
IAF-export@donaldson.com +44 116 269 6161

