

Donaldson
Torit®

Downflo® Oval

High Vacuum DFO 2-4

Installation and Operation Manual

Installation, Operation, and Service Information

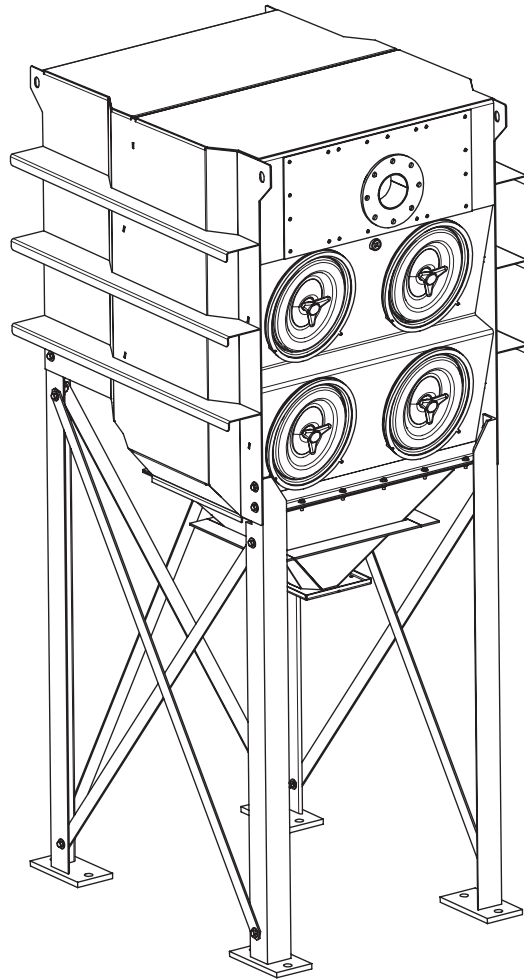

This manual is property of the owner. Leave with the unit when set-up and start-up are complete. Donaldson Company reserves the right to change design and specifications without prior notice.

Illustrations are for reference only as actual product may vary.



This is the safety alert symbol. It is used to alert you to potential personal injury hazards. Obey all safety messages that follow this symbol to avoid possible injury or death.

English
Master Language

IOM AK0302001
Revision 2

WARNING

Process owners/operators have important responsibilities relating to combustible hazards. Process owners/operators must determine whether their process creates combustible dust, fume, or mist. If combustible dust, fume, or mist is generated, process owners/operators should at a minimum:

- Comply with all applicable codes and standards. Among other considerations, current NFPA standards require owners/operators whose processes involve potentially combustible materials to have a current Hazard Analysis, which can serve as the foundation for their process hazard mitigation strategies.
- Prevent all ignition sources from entering any dust collection equipment.
- Design, select, and implement fire and explosion mitigation, suppression, and isolation strategies that are appropriate for the risks associated with their application.
- Develop and implement maintenance work practices to maintain a safe operating environment, ensuring that combustible dust, fume, or mist does not accumulate within the plant.

Donaldson recommends process owners/operators consult with experts to insure each of these responsibilities are met.

As a manufacturer and supplier of Industrial Filtration Products, Donaldson can assist process owners/operators in the selection of filtration technologies. However, process owners/operators retain all responsibility for the suitability of fire and explosion hazard mitigation, suppression, and isolation strategies. Donaldson assumes no responsibility or liability for the suitability of any fire and/or explosion mitigation strategy, or any items incorporated into a collector as part of an owner/operators hazard mitigation strategy.

Improper operation of a dust control system may contribute to conditions in the work area or facility that could result in severe personal injury and product or property damage. Check that all collection equipment is properly selected and sized for the intended use.

DO NOT operate this equipment until you have read and understand the instruction warnings in the Installation and Operations Manual. For a replacement manual, contact Donaldson Torit.

This manual contains specific precautionary statements relative to worker safety. Read thoroughly and comply as directed. Discuss the use and application of this equipment with a Donaldson Torit representative. Instruct all personnel on safe use and maintenance procedures.

Data Sheet

Model Number _____	Serial Number _____
Ship Date _____	Installation Date _____
Customer Name _____	
Address _____ _____	
Filter Type _____	
Accessories _____	
Other _____	

Contents

Description.....	1	Optional Equipment.....	19
Purpose and Intended Use	1	Magnehelic® Gauge.....	19
Rating and Specification Information.....	2	Photohelic® Gauge	20
Operation.....	3	Delta P C-01 Control	22
Inspection on Arrival.....	4	Explosion Vent & Sprinkler	23
Installation Codes and Procedures	4	Troubleshooting	24
Installation.....	4	Service Notes	27
Site Selection, Grade-Mounted Units.....	4		
Unit Location	4		
Rigging Instructions.....	5		
Hoisting Information	5		
Electrical Wiring.....	5		
Typical Installation.....	6		
Standard Equipment.....	7		
Hopper Assembly.....	7		
Leg Assembly.....	7		
Provisional Anchor Bolt Recommendations	8		
Compressed Air Installation	9		
Solid-State Timer Installation.....	11		
Solenoid Connection.....	11		
Timer and Solenoid Specifications.....	11		
Preliminary Start-Up Check	13		
Maintenance Information.....	15		
Operational Checklist	15		
Filter Removal and Installation.....	15		
Filter Removal	15		
Filter Installation.....	17		
Dust Disposal.....	17		
Compressed Air Components.....	17		

Magnehelic® and Photohelic® are registered trademarks of Dwyer Instruments, Inc.



DANGER

DANGER indicates a hazardous situation which, if not avoided, will result in death or serious injury.



WARNING

WARNING indicates a hazardous situation which, if not avoided, could result in death or serious injury.



CAUTION

CAUTION, used with the safety alert symbol, indicates a hazardous situation which, if not avoided, could result in minor or moderate injury.

NOTICE

NOTICE is used to address practices not related to personal injury that may result in damage to equipment.

Description

The Downflo Oval, Model high vacuum DFO 2-4 is continuous-duty dust collector with oval, cartridge-style filters. The downward airflow design delivers high filtration efficiency while using less energy. Continuous-duty means no downtime. The filters are pulse-cleaned in sequence, one set at a time, without turning the unit off. This model is two filters wide by two filters high by one filter deep.

Designed to increase the versatility of the unit, standard options include top, front inlets.

Purpose and Intended Use



Misuse or modification may result in severe personal injury and/or

property damage.

Do not misuse or modify.

Downflo Oval collector is widely used on nuisance dust where the load to the collector is less than 5 grains per cubic foot. Some typical applications include abrasive blasting, grinding, pharmaceuticals, powder paint applications, sand handling, and welding. Each application is different and selecting the correct filter cartridge for the application and type of dust collected is important.

- For all ambient, extremely fine, and non-fibrous dust, use Ultra Web® filter cartridges which offer high efficiency and performance on fine particulate.
- For fibrous dust, use a cartridge with an open-pleat design, such as Fibra-Web®.
- Operations involving high temperature and high humidity may require special attention. Temperature, moisture content, and chemistry issues may require custom collector design.
- Hygroscopic dust such as fertilizer, salt, and sugar should be handled under a controlled, low humidity environment.
- Flammable or explosive dust may require custom collector design options .
- Applications with high hydrocarbon or high oil content may require special treatment or filter media.



Combustible materials such as buffing lint, paper, wood, metal dusts, weld fume, or flammable coolants or solvents represent potential fire and/or explosion hazards. Use special care when selecting, installing, and operating all dust, fume, or mist collection equipment when such combustible materials may be present in order to protect workers and property from serious injury or damage due to a fire and/or explosion.

Consult and comply with all National and Local Codes related to fire and/or explosion properties of combustible materials when determining the location and operation of all dust, fume, or mist collection equipment.

Standard Donaldson Torit equipment is not equipped with fire extinguishing or explosion protection systems.

Rating and Specification Information

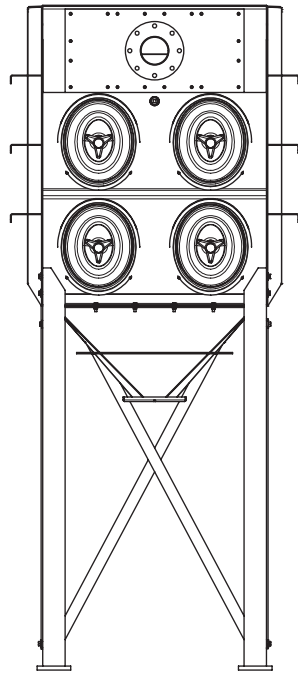

High vacuum DFO2-4

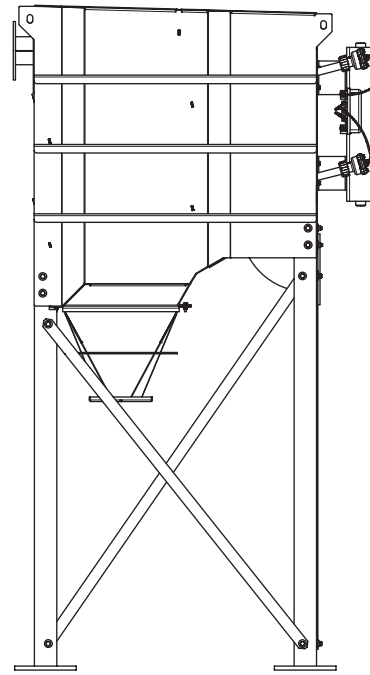

Side view

All Units (as per IBC 2009 Specifications*):

Seismic Spectral Acceleration, S 1.5 g
 Seismic Spectral Acceleration, S_1^s 0.6 g
 Installed Unit Base Elevation Grade
 Occupancy Category II
 Compressed air, maximum psig 90
 Housing rating, inches water gauge -197
 Power, valves and controls 220-Volt 50/60 Hz

*If unit was supplied with a Record Drawing, the specifications on the drawing will supersede the standard specifications above.

Operation

During normal operation, dust-laden air enters the unit through the dirty-air inlet. Airflow is directed downward through the collector and heavier particulate falls directly into the hopper. The cartridges remove fine particulate and clean, filtered air passes through the cartridge to the clean-air plenum and discharges through the clean-air outlet.

Filter cleaning is completed using pulse-jet technology. A solenoid and air diaphragm valve aligned to each filter provides the pulse cleaning. The cleaning sequence starts at the top filter and continues down through each filter. Remove, inspect, or change the filter cartridges from outside the unit by removing the filter access cover and sliding the filter out.

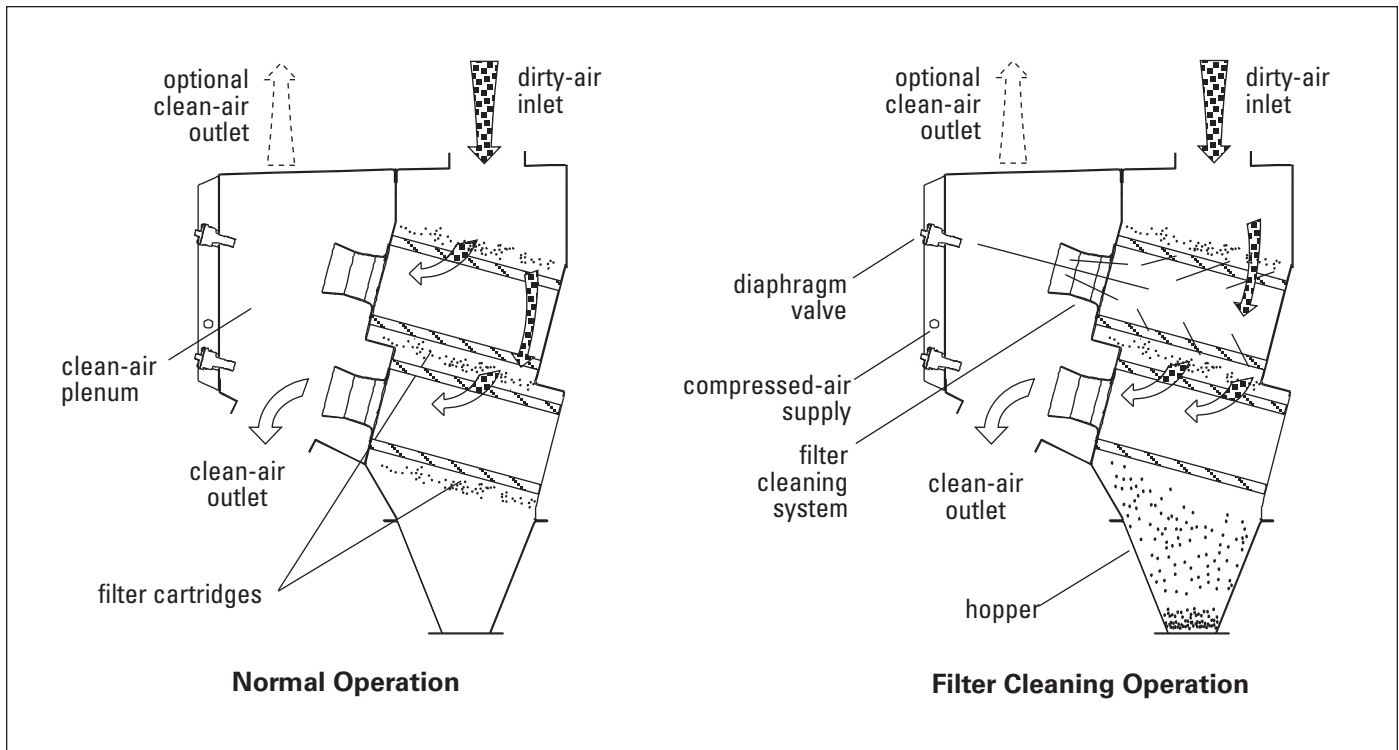

Unit Operation

Inspection on Arrival

1. Inspect unit on delivery.
2. Report any damage to the delivery carrier.
3. Request a written inspection report from the Claims Inspector to substantiate any damage claim.
4. File claims with the delivery carrier.
5. Compare unit received with description of product ordered.
6. Report incomplete shipments to the delivery carrier and your Donaldson Torit representative.
7. Remove crates and shipping straps. Remove loose components and accessory packages before lifting unit from truck.
8. Check for hardware that may have loosened during shipping.
9. Use caution removing temporary covers.

Installation Codes and Procedures

CAUTION

Codes may regulate recirculating filtered air in your facility.

Consult with the appropriate authorities having jurisdiction to ensure compliance with all national and local codes regarding recirculating filtered air.

Safe and efficient operation of the unit depends on proper installation.

Authorities with jurisdiction should be consulted before installing to verify local codes and installation procedures. In the absence of such codes, install unit according to the National Electric Code, NFPA No. 70-latest edition and NFPA 91 (NFPA 654 if combustible dust is present).

A qualified installation and service agent must complete installation and service of this equipment.

All shipping materials, including shipping covers, must be removed from the unit prior to, or during unit installation.

NOTICE

Failure to remove shipping materials from the unit will compromise unit performance.

Inspect unit to ensure all hardware is properly installed and tight prior to operating collector.

Installation

WARNING

Use proper equipment and adopt all safety precautions needed for servicing equipment.

Electrical service or maintenance work must be performed by a qualified electrician and comply with all applicable national and local codes.

Turn power off and lock out electrical power sources before performing service or maintenance work.

Do not install in classified hazardous atmospheres without an enclosure rated for the application.

Turn compressed air supply OFF, bleed and lock out lines before performing service or maintenance work.

CAUTION

Site selection must account for wind, seismic zone, and other

load conditions when selecting the location for collectors.

Codes may regulate acceptable locations for installing dust collectors. Consult with the appropriate authorities having jurisdiction to ensure compliance with all national and local codes regarding dust collector installation.

Collectors must be anchored in a manner consistent with local code requirements. Anchors must be sufficient to support dead, live, seismic, and other anticipated loads.

Consult a qualified engineer for final selection of anchorage.

NOTICE

Do not set compressed-air pressure above 100-psig as component damage can occur.

All compressed air components must be sized to meet the system requirements of 90-100-psig supply pressure.

The compressed-air supply must be oil and moisture free. Contamination in the compressed air used to clean filters will result in poor cleaning, cleaning valve failure, or poor collector performance.

Purge compressed air lines to remove debris before connecting to the collector's compressed air manifold.

The collector is suitable for either indoor or outdoor installations. Reference the Rating and Specification Information.

Foundations or Support Framing

Prepare the foundation or support framing in the selected location. Foundation or support framing must comply with local code requirements and may require engineering.

Foundation and support framing must be capable of supporting dead, live, wind, seismic and other applicable loads. Consult a qualified engineer for final selection of foundation or support framing.

Collector Location



WARNING

Donaldson Torit equipment is not designed to support site installed ducts, interconnecting piping, or electrical services. All ducts, piping, or electrical services must be adequately supported to prevent severe personal injury and/or property damage.

When hazardous conditions or materials are present, consult with local authorities for the proper location of the collector.



CAUTION

Dust collection equipment may reach peak sound pressure levels above 80 dB (A). Noise levels should be considered when selecting collector location.

Locate the collector to ensure easy access to electrical and compressed air connections, to simplify solids collection container handling and routine maintenance, and to ensure the straightest inlet and outlet ducts.

Site Selection

This collector can be located on a foundation or structural framing.

Provide clearance from heat sources and avoid any interference with utilities when selecting the location.

Portable collectors require special installation accommodations.

Note: Collectors with explosion vents are not available in portable configurations.

Rigging Instructions

Suggested Tools & Equipment

Clevis Pins and Clamps	Lifting Slings
Crane or Forklift	Pipe Sealant
Drift Pins	Pipe Wrenches
Drill and Drill Bits	Screwdrivers
End Wrenches	Socket Wrenches
Adjustable Wrench	Spreader Bars
Torque Wrench (inch/lbs, 9/16-in Socket)	

Hoisting Information



WARNING

Failure to lift the collector correctly can result in severe personal injury and/or property damage.

Use appropriate lifting equipment and adopt all safety precautions needed for moving and handling the equipment.

A crane or forklift is recommended for unloading, assembly, and installation of the collector.

Location must be clear of all obstructions, such as utility lines or roof overhang.

Use all lifting points provided.

Use clevis connectors, not hooks, on lifting slings.

Use spreader bars to prevent damage to collector's casing.

Check the Specification Control drawing for weight and dimensions of the collector and components to ensure adequate crane capacity.

Allow only qualified crane or forklift operators to lift the equipment.

Refer to applicable OSHA regulations and local codes when using cranes, forklifts, and other lifting equipment.

Lift collector and accessories separately and assemble after collector is in place.

Use drift pins to align holes in section flanges during assembly.

Typical Installation

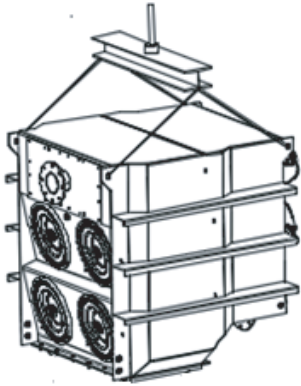

1. Lift cabinet.
2. Apply sealant to hopper flange.
3. Fasten hopper to cabinet.

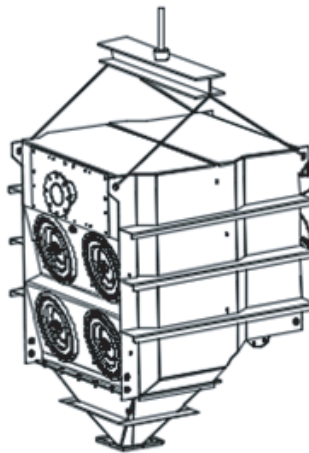

4. Assemble legs and cross braces.
5. Lift unit and hopper into position over legs and lower slowly.
6. Fasten legs to unit securely.

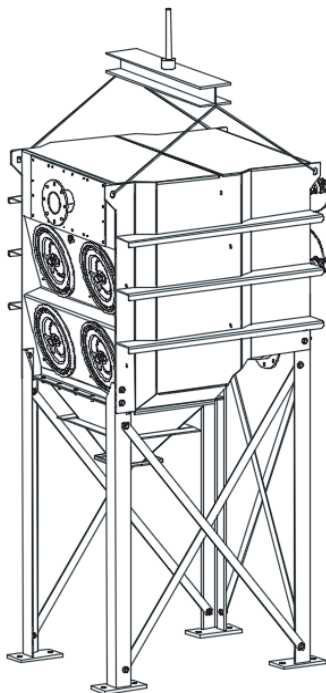
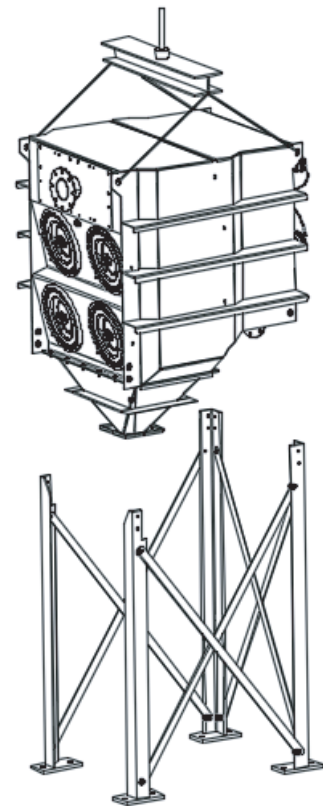

7. Lift assembled unit to location.
8. Support and level unit.
9. Tighten all fasteners.
10. Remove crane.

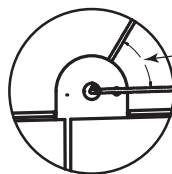

angle not to exceed 30° from vertical (min 60° from horizontal)



Do Not lift with this orientation

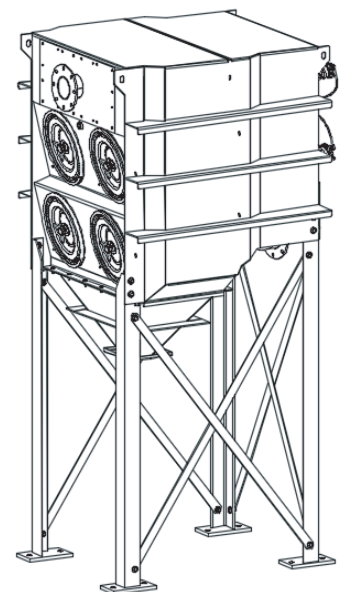

Typical Installation

Standard Equipment

Standard equipment consists of a collector cabinet, hopper, and legs. Basic assembly starts by attaching the hopper to the cabinet, then attaching the legs. A detailed instruction drawing, shipped with each collector, provides specific assembly and lifting instructions.

Hopper Assembly

Assemble the standard hopper following these instructions.

1. Stand the hopper on the discharge end.
2. Apply 1/4-in diameter rope-type sealant around the top flange toward the inside edge of the bolt pattern.
3. Lift the collector and position over the hopper and lower slowly.
4. Use drift pins to align holes.
5. Secure collector to hopper using 3/8-16 x 1 1/4-in bolts, flat washers, and nuts. Tighten all hardware securely. See Hopper Installation below.

Leg Installation



Anchors must comply with local code requirements and must be capable of supporting dead, live, wind, seismic, and other applicable loads.

Anchor sizes shown are provisional, as final anchor sizing will depend on jobsite load conditions, collector location, foundation/framing design variables and local codes.

Consult a qualified engineer for final selection of suitable anchors.

Leg sets for standard collector sizes are shown in the Rating and Specification Information. Reference Typical Foundation Anchor and leg assembly drawing shipped with the collector prior to starting assembly.

1. Prepare the foundation or support framing in the selected location. Locate and install anchors.
2. Position and assemble legs and cross braces as shown in Leg and Cross Brace Assembly.

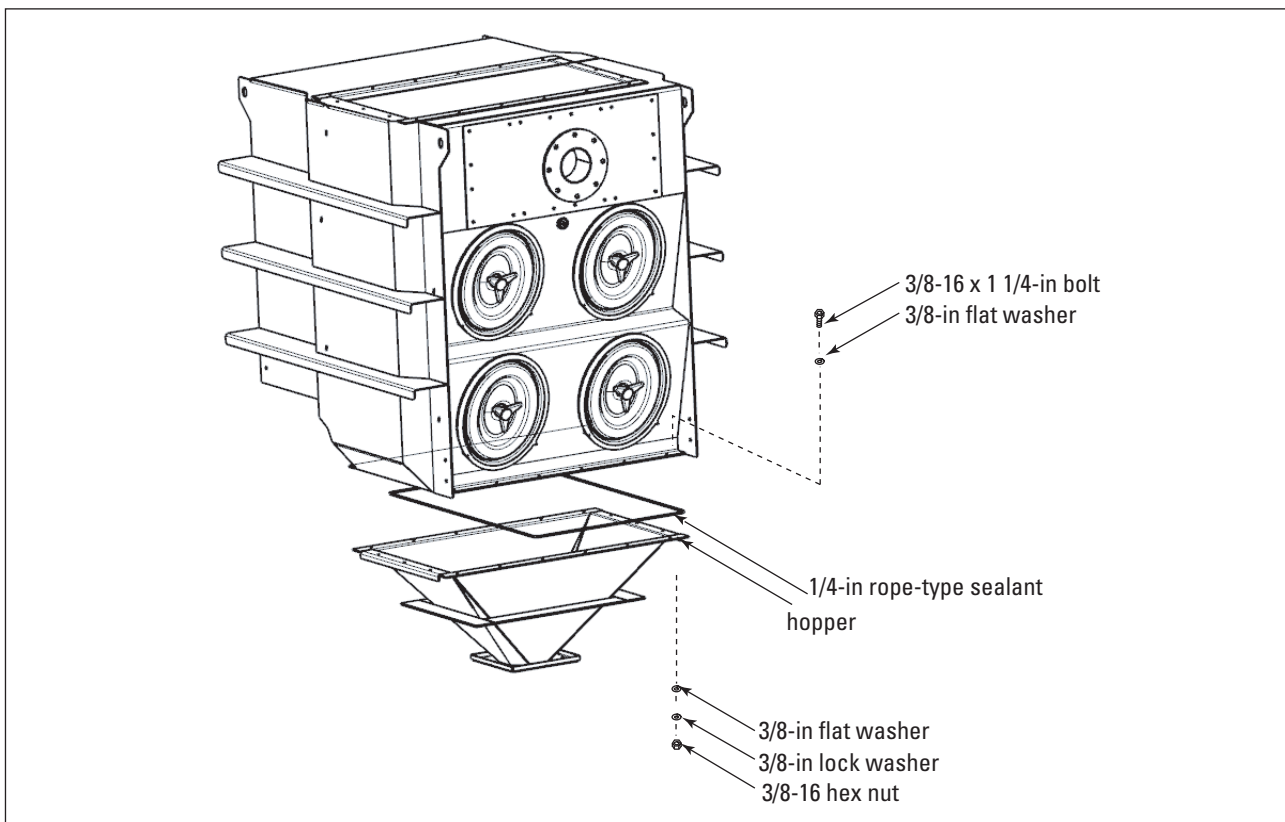

Hopper Installation

Provisional Anchor Bolt Recommendations

3. Lift the cabinet and hopper assembly into position over the legs and lower slowly.
4. Use drift pins to align the holes in the collector with the holes in the legs. Attach each leg as shown using the hardware supplied. Do not tighten hardware at this time.
5. Recheck the position of the leg sets and cross braces.
6. Using a crane, lift the assembled unit onto the anchor bolts. Fasten each leg pad to the anchor bolts using flat washers, lock washers, and hex nuts provided by others. Do not tighten hardware at this time.
7. Level unit. Tighten all hardware on legs, cross braces, and foundation anchors.

NOTICE

Tighten all hardware before removing crane to prevent personal injury or property damage.

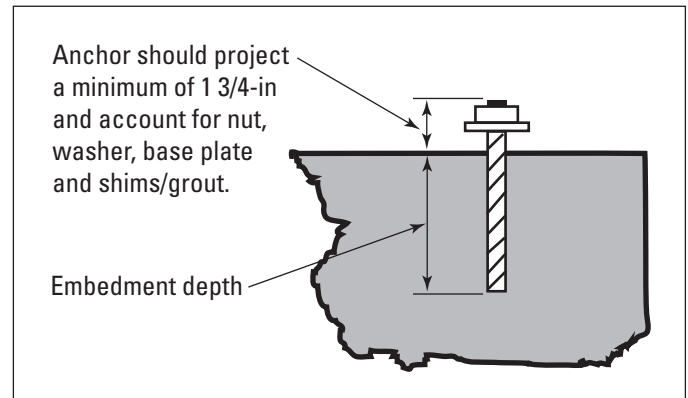

Anchor should project a minimum of 1 3/4-in and account for nut, washer, base plate and shims/grout.

Embedment depth

Typical Foundation Anchor

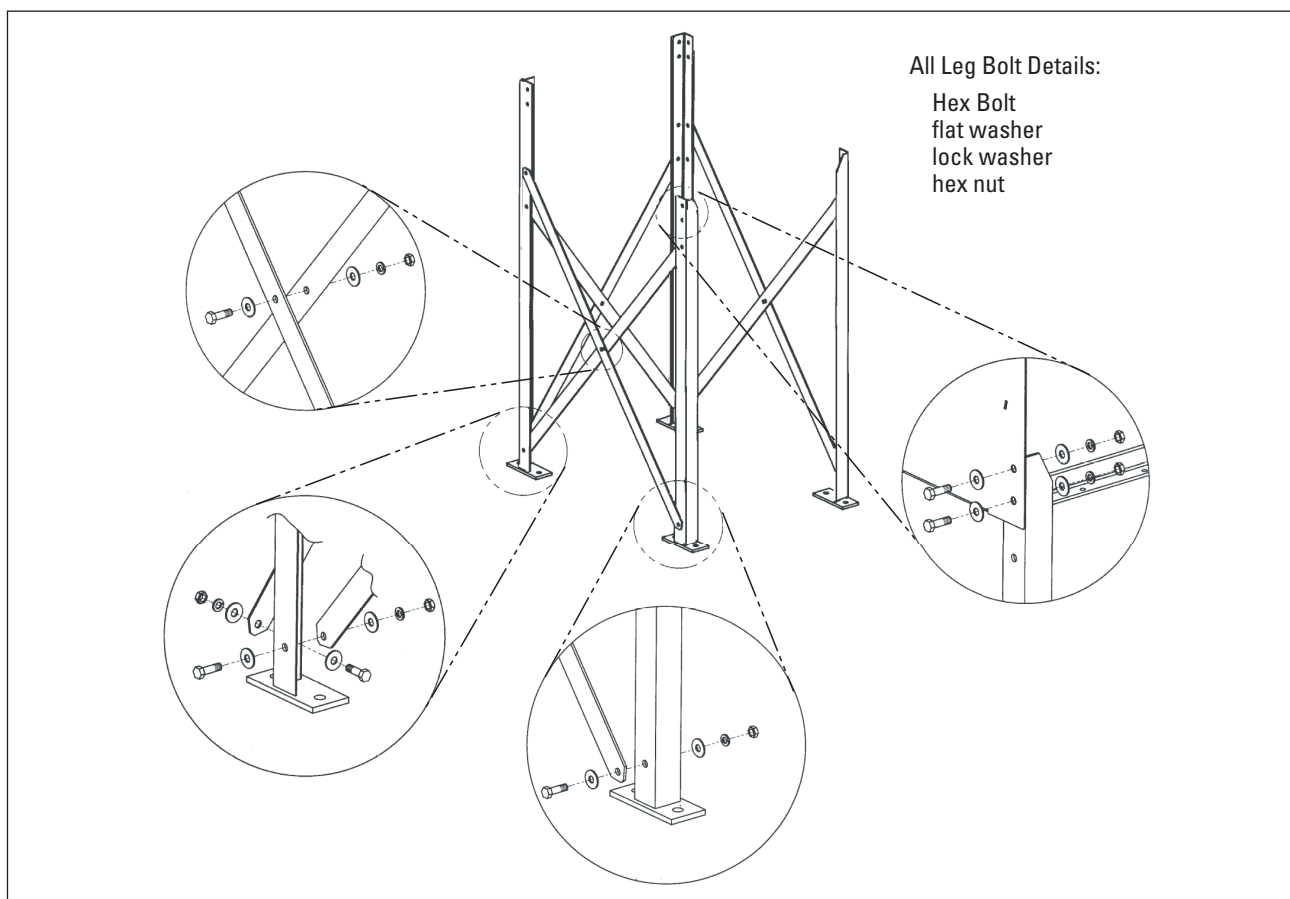

All Leg Bolt Details:

Hex Bolt
flat washer
lock washer
hex nut

Leg and Cross Brace Assembly

Compressed Air Installation

WARNING

Turn compressed-air supply OFF and bleed lines before performing service or maintenance work.

A safety exhaust valve should be used to isolate the compressed air supply. The safety exhaust valve should completely exhaust downstream pressure when closed and include provisions to allow closed-position locking.

NOTICE

Do not set compressed-air pressure above 90-psfig.

Component damage can occur.

All compressed air components must be sized to meet the maximum system requirements of 1.58 cu ft/pulse at 90 psig supply pressure

The compressed-air supply must be oil and moisture free. Contamination in the compressed air used to clean filters will result in poor cleaning, cleaning valve failure, or poor collector performance.

Purge compressed-air lines to remove debris before connecting to the unit's compressed-air manifold.

1. Remove the 1-in pipe cap from one of the unit's two air manifolds and connect the compressed-air supply line. Use thread-sealing tape or pipe sealant on all compressed-air connections.
2. Install a customer-supplied shut-off valve, bleed-type regulator with gauge, filter, and automatic condensate valve in the compressed-air supply line.

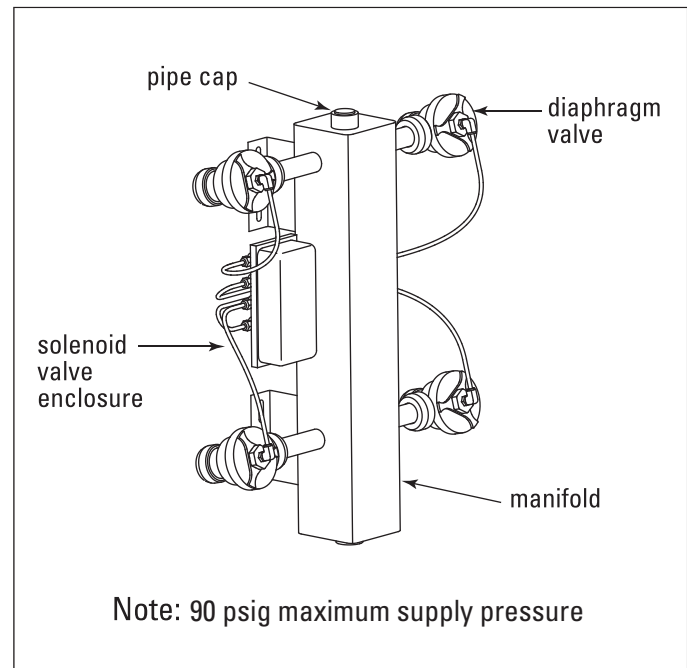

Manifold

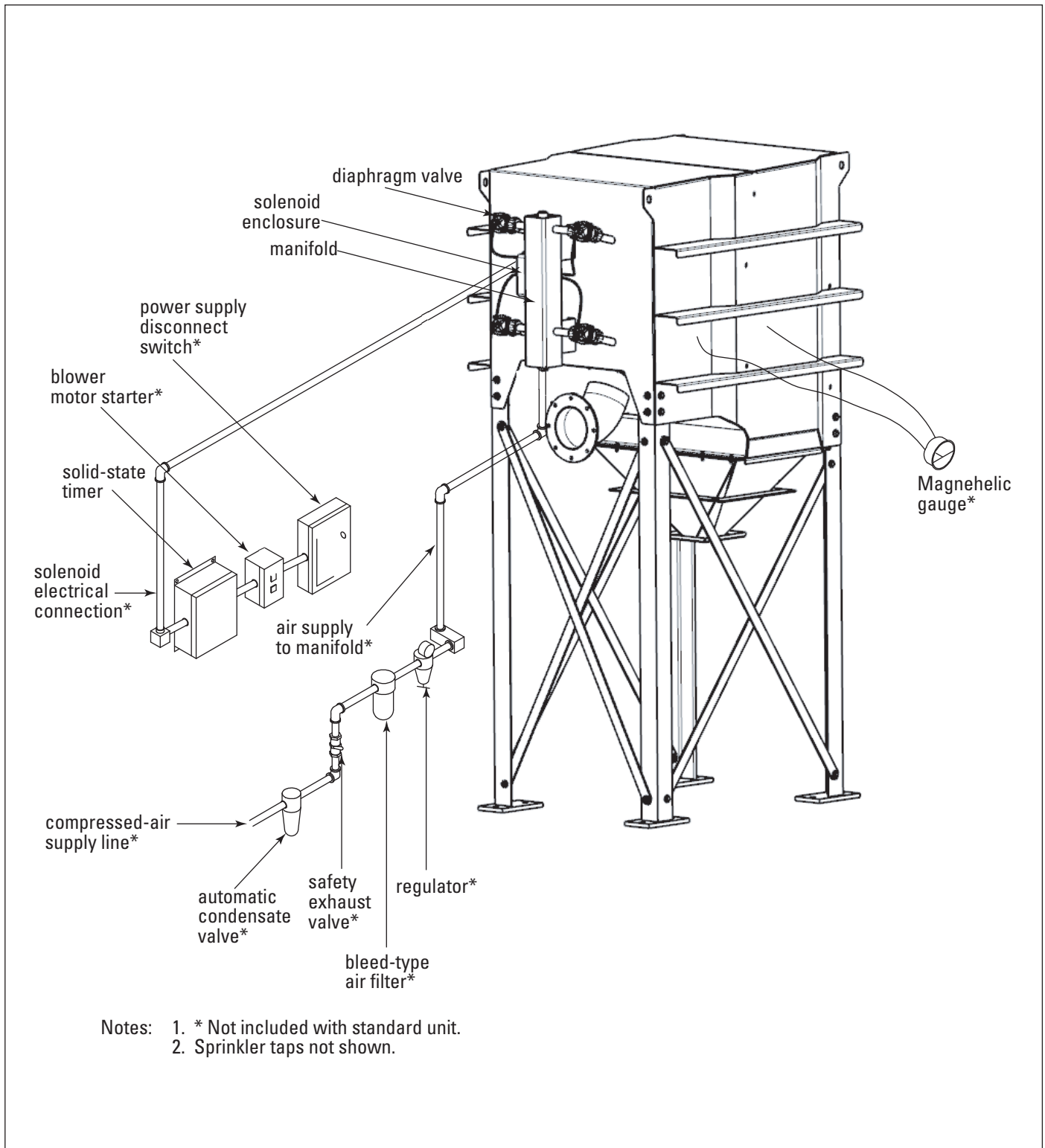

Compressed Air and Component Installation

Solid-State Timer Installation

! WARNING

Electrical installation must be performed by a qualified electrician and comply with all applicable national and local codes.

Turn power off and lock out electrical power sources before performing installation, service, or maintenance work.

Do not install in classified hazardous atmospheres without an enclosure rated for the application.

The solid-state timer is an electronic timer used to control the filter cleaning system.

1. Using the wiring diagram supplied, wire the blower motor, blower-motor starter, solid-state timer, and solenoid valves. Use appropriate wire gauge for rated amp load as specified by local codes.
2. Plug the program lug into the pin that corresponds with the number of solenoid valves controlled.
3. With power supply ON, check the operation of the solenoid valves. The valves should open and close sequentially at factory set 10-second intervals.
4. If a Photohelic gauge or similar device is used to control the solid-state timer and the jumper on the pressure switch portion of the timer is removed, the solenoid valves pulse only when the differential pressure reaches the high-pressure setpoint. The valves continue to pulse until the low-pressure setpoint is reached.

NOTICE

The solid-state timer requires a 220-Volt customer-supplied power supply.

Do not mount the solid-state timer directly to the unit. Mechanical vibration can damage the control.

Solenoid Connection

The unit is equipped with 220-Volt solenoid valves that control the pulse-cleaning valves, which clean the filters.

One of three types of solenoid enclosures, the weatherproof NEMA 4 with 1/8-in solenoid valves; the gas-explosion proof NEMA 7 with 1/8-in solenoid valves; or the dust-explosion proof NEMA 9 with 1/8-in solenoid valves, is mounted near or on the unit's compressed-air manifold.

Wire the solenoids to the solid-state timer following the wiring diagram supplied with the unit. Filter life and cleaning operation will be affected if not wired correctly.

Timer and Solenoid Specifications

Power to the solid-state timer is supplied to Terminals L1 and L2, which operate in parallel with the blower starter's low-voltage coil. On blower start-up, power is supplied to the timer and the preset OFF time is initiated. At the end of the OFF time, the timer energizes the corresponding solenoid valve to provide the ON time cleaning pulse for one diaphragm valve and then steps to the next until all filters have been cleaned.

To pulse when the blower is OFF, install a toggle switch as shown on the Solid-State Timer Wiring Diagram. When the toggle switch is ON, the timer receives power and energizes the solenoid valves' pulse-cleaning operation even though the blower is turned OFF.

Input
200/240V/50/60Hz

Output Solenoids
The load is carried and turned ON and OFF by the 200 watt maximum-load-per-output solid-state switch.

Pulse ON Time
Factory set at 100-milliseconds, or 1/10-second.

NOTICE Do not adjust pulse ON time unless the proper test equipment is available. Too much or too little ON time can cause shortened filter life.

Pulse OFF Time - Factory set at 10-seconds, adjustable from 1 to 1.5-second minimum to maximum 60 to 66-second.

Solenoid Valves
220-Volt at 23.1 watts each

Compressed-Air
Set compressed-air supply at 90-psig. The timer is factory set to clean one filter or set of filters every 10-seconds.

NOTICE Do not increase supply pressure above 90-psig. Component damage can occur.

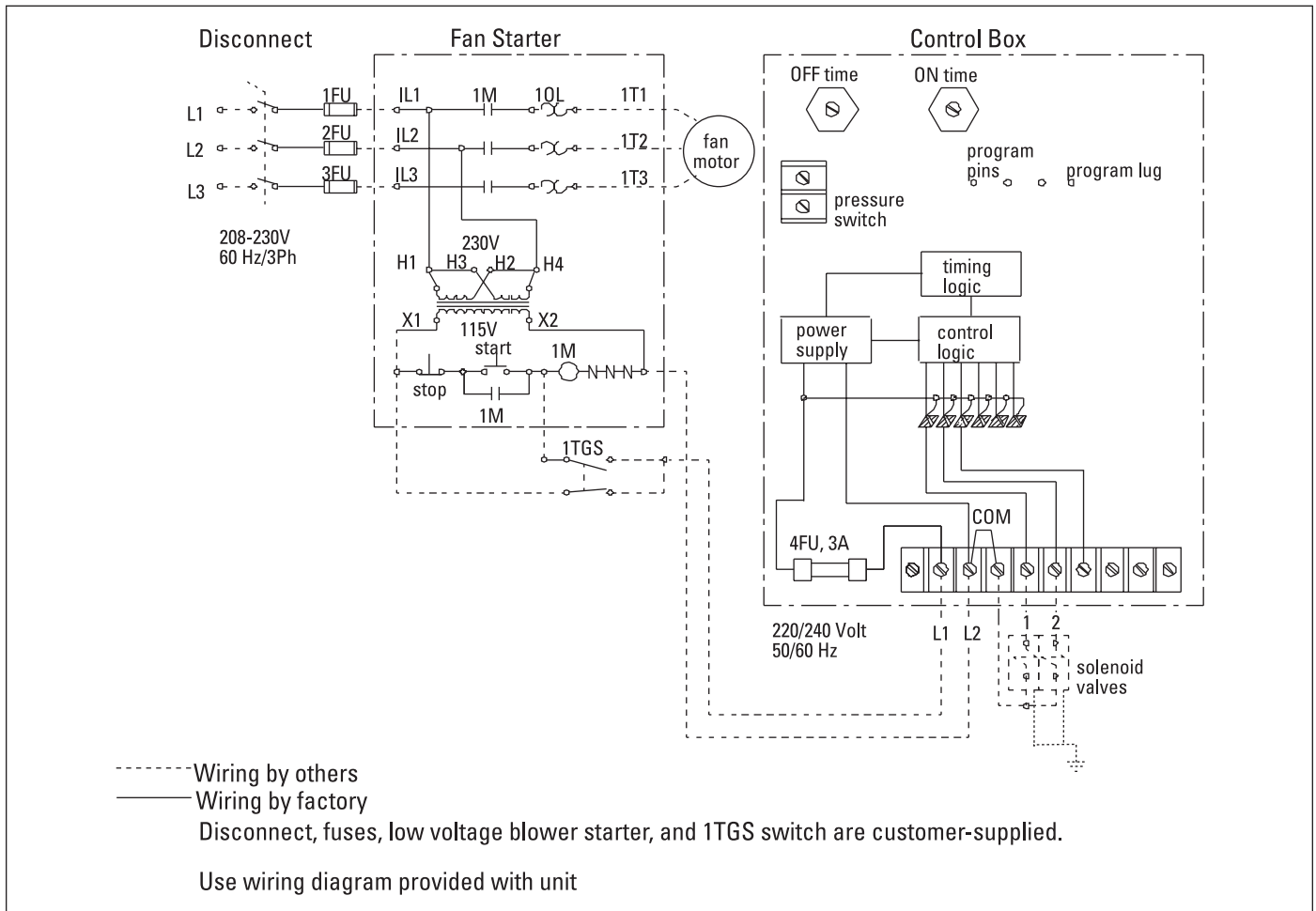

Solid-State Timer Typical Wiring Diagram

Preliminary Start-Up Check

Instruct all personnel on safe use and maintenance procedures.

WARNING

Electrical work during installation must be performed by a qualified electrician and comply with all applicable national and local codes.

Turn power off and lock out electrical power sources before performing service or maintenance work.

Turn compressed air supply OFF and bleed lines before performing service or maintenance work.

Check that the collector is clear and free of all debris before starting.

Do not install in classified hazardous atmospheres without an enclosure rated for the application.

1. Check all electrical connections for tightness and contact.
2. Motor and fan should be wired for clockwise rotation when viewed from the back of the motor.

To reverse rotation, single-phase power supply:
Follow manufacturer's instructions on the motor's nameplate.

To reverse rotation, three-phase power supply:
Turn electrical power OFF at source and switch any two leads on the motor junction box.

WARNING

Do not interchange a power lead with the ground wire. Severe damage or personal injury may result.

3. All access panels should be sealed and secure.
4. Check that the dust container is properly sealed and clamped.
5. Check that exhaust damper is set to the fully-closed position.

6. Check and remove all loose items in or near the inlet and outlet of the unit.
7. Check that all remote controls and solenoid enclosures (if applicable) are properly wired and all service switches are in the OFF position.
8. Check that all optional accessories are installed properly and secured.
9. Turn power ON at source.
10. Turn the compressed-air supply ON. Adjust pressure regulator for 90-psig.
11. Turn blower fan motor ON.

WARNING

Do not look into fan outlet to determine rotation. View the fan rotation through the back of the motor.

Check that the exhaust plenum is free of tools or debris before checking blower/fan rotation.

Stand clear of exhaust to avoid personal injury.

12. Adjust airflow with the exhaust damper.

NOTICE

Excess airflow can shorten filter life, cause electrical system failure, and blower motor failure.

13. Turn Powered hopper discharge devices ON.

This Page Intentionally Left Blank

Maintenance Information

Instruct all personnel on safe use and maintenance procedures.

WARNING

Use proper equipment and adopt all safety precautions needed

for servicing equipment. Electrical service or maintenance work must be performed by a qualified electrician and comply with all applicable national and local codes.

Turn power off and lock out electrical power sources before performing service or maintenance work.

Do not install in classified hazardous atmospheres without an enclosure rated for the application.

Turn compressed air supply OFF and bleed lines before performing service or maintenance work.

NOTICE

Do not set compressed-air pressure above 90-psig.

Component damage can occur.

All compressed air components must be sized to meet the maximum system requirements of 90-psig supply pressure.

The compressed-air supply must be oil and moisture free. Contamination in the compressed air used to clean filters will result in poor cleaning, cleaning valve failure, or poor collector performance.

Purge compressed air lines to remove debris before connecting to the unit's compressed air manifold.

Operational Checklist

1. Monitor the physical condition of the collector and repair or replace any damaged components.

Routine inspections will minimize downtime and maintain optimum system performance. This is particularly important on continuous-duty applications.

2. Periodically check the compressed air components and replace compressed air filters.

Drain moisture following the manufacturer's instructions. With the compressed air supply ON, check the cleaning valves, solenoid valves, and tubing for leaks. Replace as necessary.

3. Monitor pressure drop across filters.

Abnormal changes in pressure drop indicate a change in operating conditions and possibly a fault to be corrected. For example, prolonged lack of compressed air will cause an excess build-up of dust on the filters resulting in increased pressure drop. Cleaning off-line with no flow usually restores the filters to normal pressure drop.

4. Monitor exhaust.

5. Monitor dust disposal.

Filter Removal and Installation

WARNING

Use proper safety and protective equipment when removing

contaminants and filters.

Dirty filters may be heavier than they appear.

Use care when removing filters to avoid personal injury.

Turn power off and lock out electrical power sources before performing service or maintenance work .

Turn compressed air supply OFF, bleed and lock out lines before performing service or maintenance work.

CAUTION

Do not operate with missing or damaged filters.

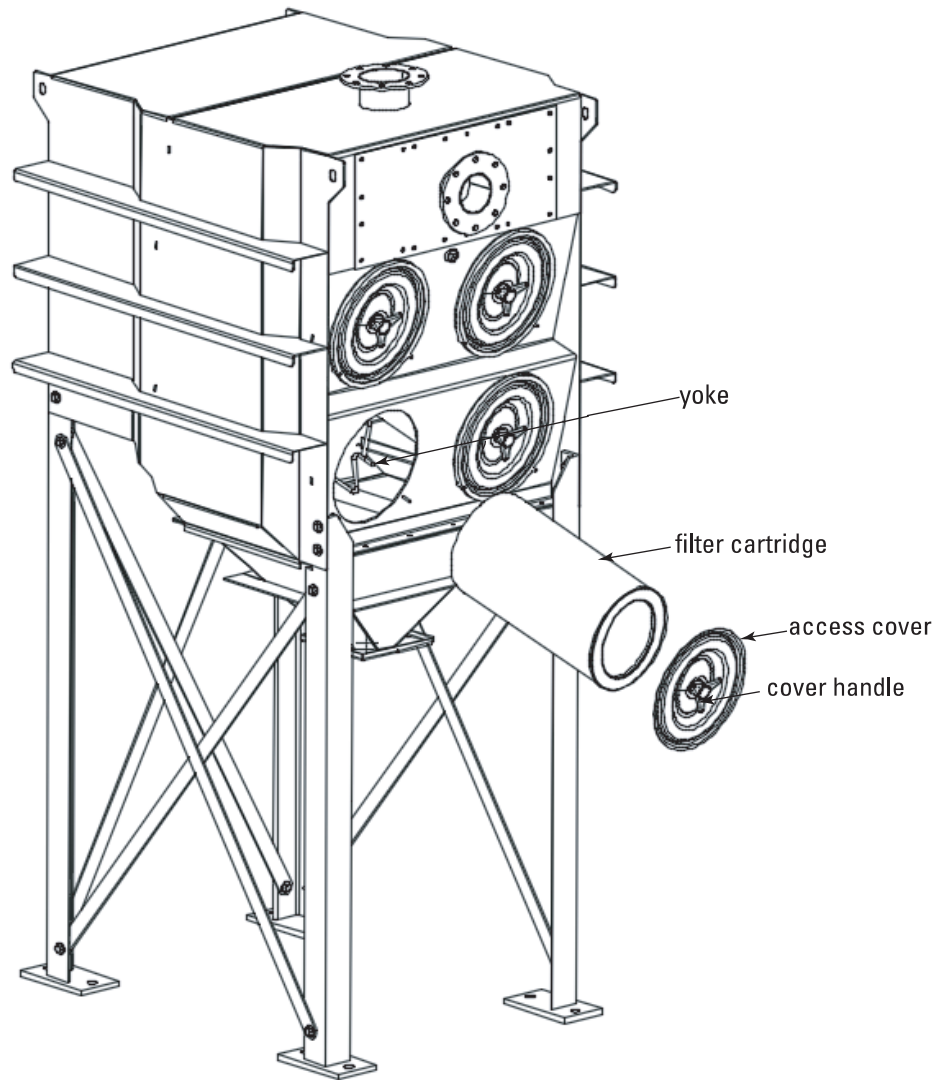

Filter Replacement

Filter Removal

1. Start at the top access port.
2. Remove access cover. For units without Bag-In/Bag-Out: remove access cover by lifting latch handle and lifting cover to remove from yoke. For units with Bag-In/Bag-Out: lift up access cover handle and while pushing in on cover, slide access cover to the side 1-inch to remove access cover. If the access cover clamp fails to operate smoothly, apply WD-40® to the riveted pivot points and to the clamp rod where it passes through the outside of the cover. Wipe off overspray.
3. Break the seal between the filter cartridge and the sealing surface.
4. Rotate the cartridge slightly to the left to remove dust that may have accumulated on the top of the filter.
5. Slide the filter out the access port along the suspension yoke and dispose of properly.
6. Clean the sealing surface with damp cloth.

NOTICE

Clean dust from gasket sealing area to ensure a positive filter gasket seal.

7. Check for an accumulation of dust in the storage area and empty as necessary.

Filter Installation

1. Slide the new filter cartridges onto each suspension yoke.

NOTICE

Insert the filter gasket end first.

2. Wipe cover gaskets clean and replace covers by attaching cover to yoke hook and firmly latching cover handle.

Replace access covers carefully by securing them using the handle provided. Keep fingers away from the sealing surface to avoid pinching.

NOTICE

Check that access covers are seated and seal properly.

Gaskets must be compressed to ensure an airtight seal.

3. Turn electrical power and compressed air supply ON before starting unit.

Dust Disposal

NOTICE

To avoid possible damage to the fan motor, maintain a seal below the collector if servicing the dust storage device while the fan is running.

1. Turn unit OFF and empty dust container as necessary to minimize dust in the hopper.
2. If the optional 55-gallon drum attachment is used, empty when drum is 2/3 full.
3. If optional slide gate is used, close gate before servicing drum.
4. Reinstall drum and open gate (if applicable).

Compressed Air Components

NOTICE

Do not set compressed-air pressure above 90-psig.

Component damage can occur.

1. Periodically check the compressed air components and replace compressed-air filter.
2. Drain moisture following the manufacturer's instructions.
3. With the compressed-air supply ON, check the cleaning valves, solenoid valves, and tubing for leaks. Replace as necessary.

This Page Intentionally Left Blank

Optional Equipment

Magnehelic® Gauge

The Magnehelic is a differential pressure gauge used to measure the pressure difference between the clean- and dirty-air chambers and provides a visual display of filter change requirements. The high-pressure tap is located in the dirty-air plenum and the low-pressure tap is located in the clean-air plenum.

1. Choose a convenient, accessible location on or near the unit for mounting that provides the best visual advantage.
2. Plug the pressure ports on the back of the gauge using two 1/8-in NPT pipe plugs supplied. Install two 1/8-in NPT male adapters supplied with the gauge into the high- and low-pressure ports on the side of the gauge. Attach the mounting bracket using three #6-32 x 1/4-in screws supplied.
3. Mount the gauge and bracket assembly to the supporting structure using two self-drilling screws.
4. Thirty-five feet of plastic tubing is supplied and must be cut in two sections. Connect one section of tubing from the gauge's high-pressure port to the pressure fitting located in the dirty-air plenum. Connect remaining tubing from the gauge's low-pressure port to the fitting in the clean-air plenum. Additional tubing can be ordered from your representative.
5. Carefully remove the cloth protecting the filters. Close access doors and tighten securely by hand.
6. Zero and maintain the gauge as directed in the manufacturer's Operating and Maintenance Instructions provided.

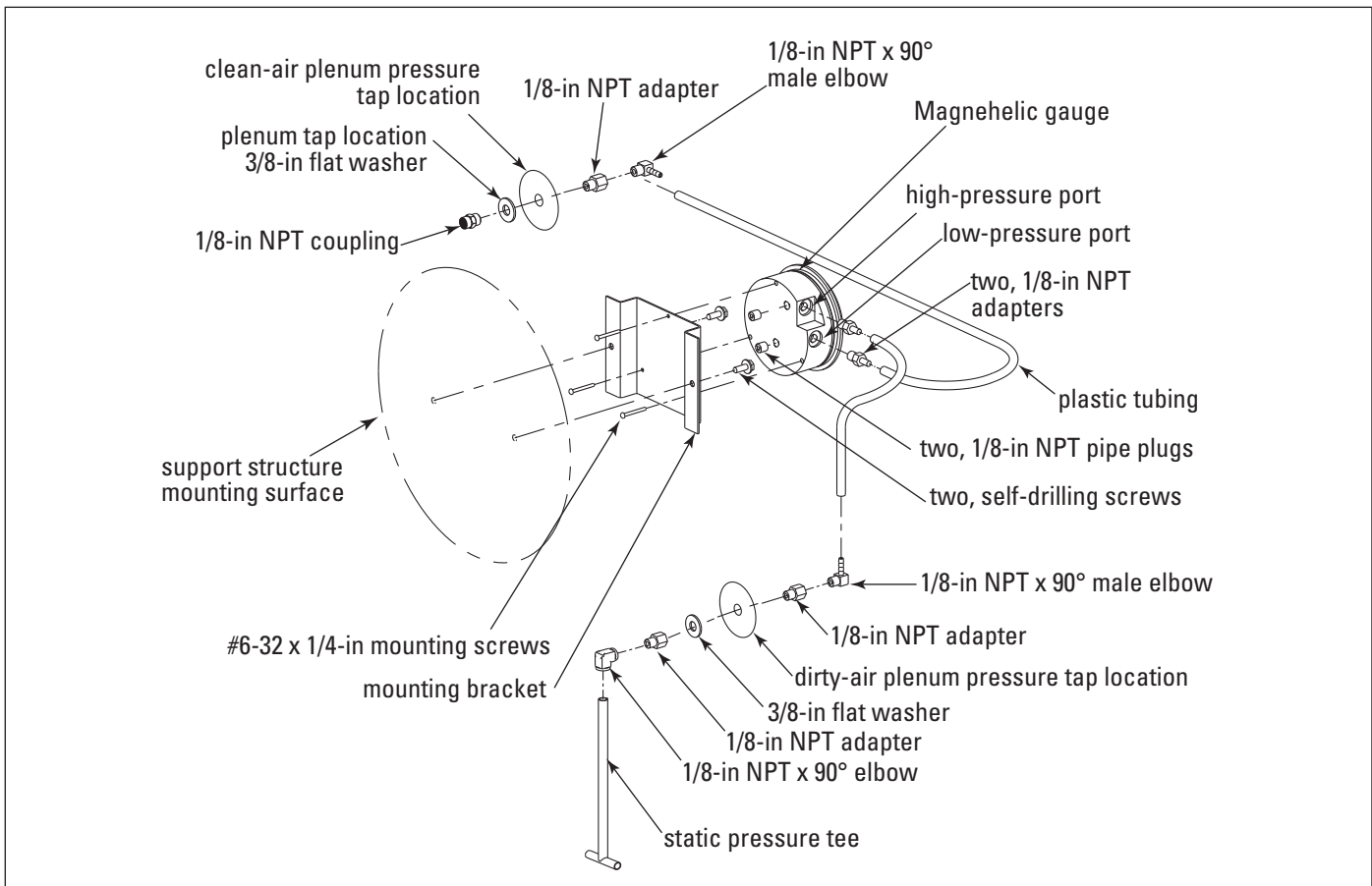

Magnehelic Gauge Installation

Photohelic® Gauge

WARNING

Electrical work must be performed by a qualified electrician and comply with all applicable national and local codes.

Turn power off and lock out electrical power sources before performing service or maintenance work.

Do not install in classified hazardous atmospheres without an enclosure rated for the application.

The Photohelic combines the functions of a differential pressure gauge and a pressure-based switch. The gauge function measures the pressure difference between the clean- and dirty-air plenum and provides a visual display of filter condition. The high-pressure tap is located in the dirty-air plenum and a low-pressure tap is located in the clean-air plenum. The pressure-based switch function provides high-pressure ON and low-pressure OFF control of the filter cleaning system.

1. Choose a convenient, accessible location on or near the unit for mounting that provides the best visual advantage.
2. Mount the gauge to the remote panel or door using the mounting ring, retaining ring, and four

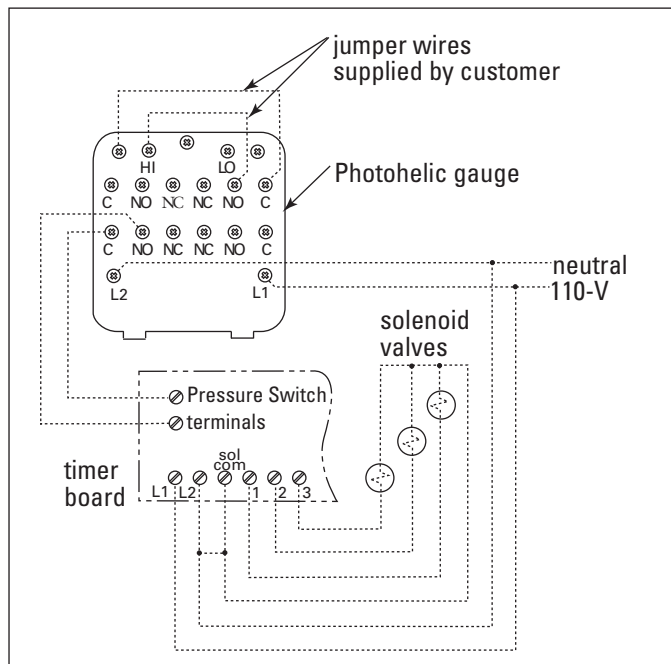

Photohelic Gauge Wiring Diagram

#6-32 x 1 1/4-in screws. Do not tighten screws. Connect two 1/8-in NPT x 1/4-in OD male adapters to the gauge's high- and low-pressure ports. Align the adapters to the 2.375-in hole in the right-hand side of the mounting bracket. Tighten screws.

3. On the back of the gauge, remove four #6-32 x 5/16-in screws and plastic enclosure. Set aside. Add two jumper wires supplied by customer. Remove the jumper from the pressure switch located on the timer board, if equipped. Using the 3/4-in conduit opening, wire the gauge as shown. Reassemble and fasten the enclosure securely.
4. Thirty-five feet of plastic tubing is supplied and must be cut in two sections. Connect one section of tubing from the gauge's high-pressure port to the pressure fitting located in the dirty-air plenum. Connect remaining tubing from the gauge's low-pressure port to the fitting in the clean-air plenum. Additional tubing can be ordered from your representative.
5. Zero and maintain the gauge as directed in the manufacturer's Operating and Maintenance Instructions provided.
6. To install the Photohelic gauge mounted in a NEMA 4, Weatherproof Enclosure, follow Steps 4 and 5.

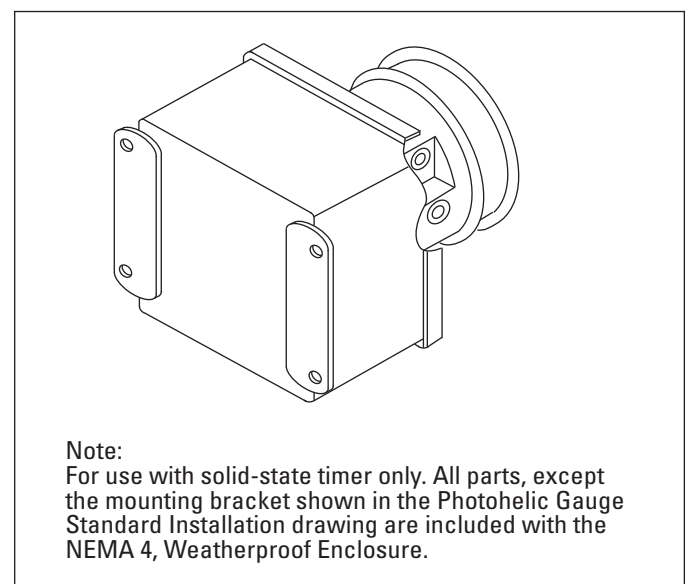

Note:
For use with solid-state timer only. All parts, except the mounting bracket shown in the Photohelic Gauge Standard Installation drawing are included with the NEMA 4, Weatherproof Enclosure.

Photohelic Gauge in Optional NEMA 4 Weatherproof Enclosure

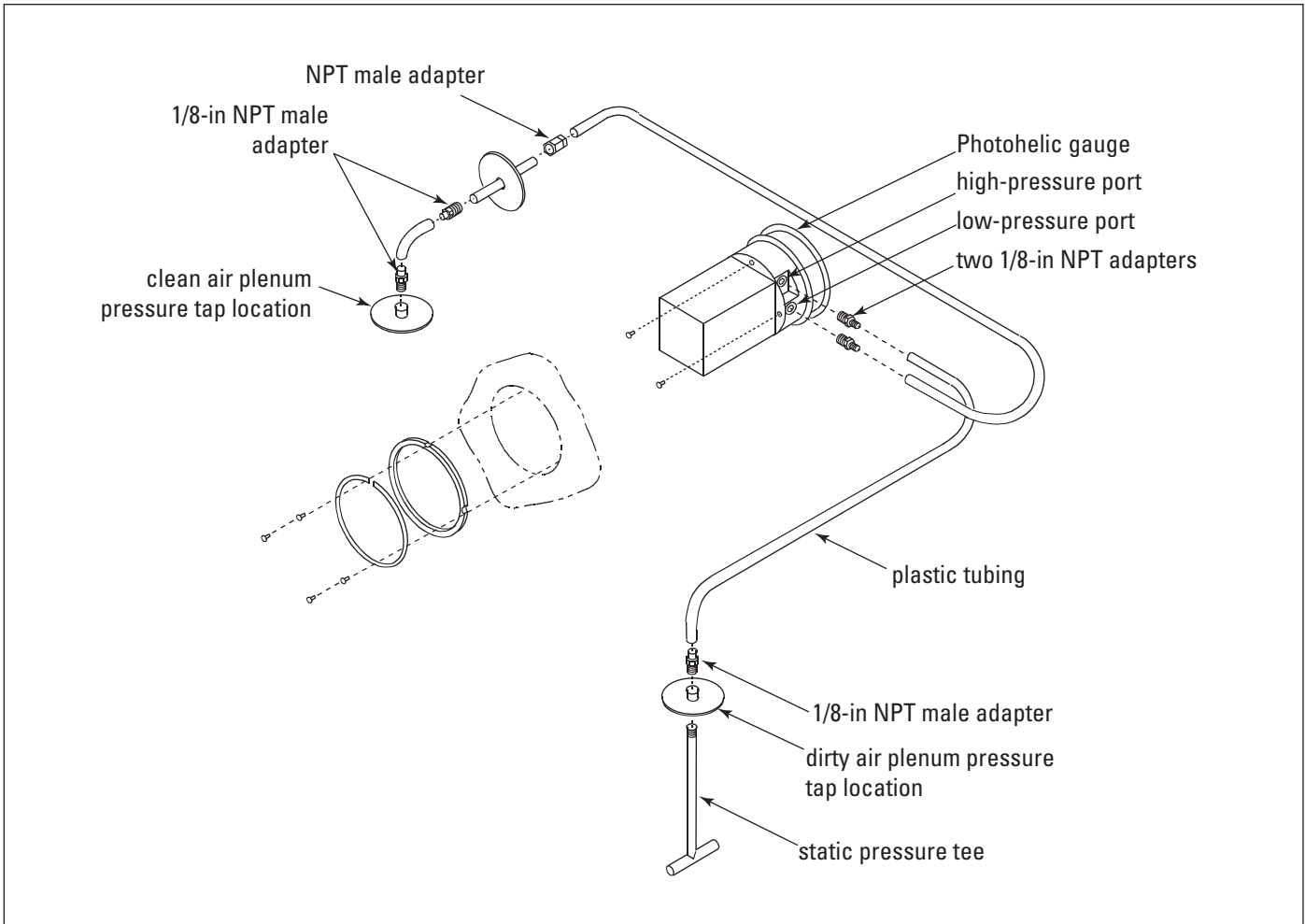

Photohelic Gauge, Remote Panel or Door Installation

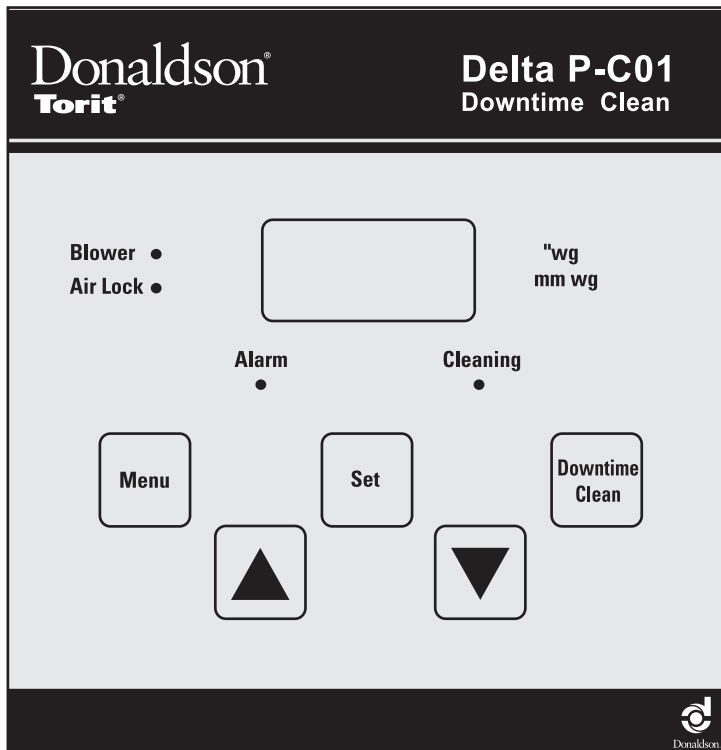

Delta P-01 Control Display

Delta P C-01 Control

The Torit Delta P C-01 Controller monitors the differential pressure between the clean and dirty air plenums, providing a visual display of the filter condition. It controls the pressure drop by turning the cleaning mechanism On and Off at the chosen limits. There are three (3) set points: High Pressure On, Low Pressure Off, and Alarm. The first two, High Pressure On and Low Pressure Off, control the filter cleaning system. The third, Alarm, provides a relay output to activate an external alarm supplied by others.

The user can program the Delta P C-01 to pulse while the collector is running to maintain a relatively constant pressure drop across the filters, pulse only after the collector is shut down (after-shift cleaning), or a combination of both, cleaning while running as well as end of shift.

For complete information, see the most current version of the Delta P C-01 Installation, Operation, and Maintenance manual.

Explosion Vents

WARNING

Personal injury, death, or property damage can result from material discharge during venting.

The material discharged during the venting of an explosion must be safely directed outdoors away from areas occupied by personnel to reduce risk of personal injury or property damage.

The risk of injury or damage can be minimized or avoided by locating vented equipment outside buildings and away from normally occupied areas.

Explosion vents should be inspected regularly to confirm physical and operational condition. Replace any damaged parts immediately.

Standard explosion vents are intended for outdoor installations only.

NOTICE

Remove all shipping materials, including covers, from the explosion relief vents prior to installation. Failure to remove shipping covers will seriously compromise explosion vent operation.

Explosion relief vents must be safely directed outdoors away from personnel, buildings, property, offices, walkways, and catwalks to reduce risk of damage to property and personal injury. Explosion venting calculations are based on formulas from NFPA-68, for outdoor applications only, with no duct or obstructions on the explosion vent panel.

Explosion vents are suitable for negative pressure installations only.

Contact Donaldson Torit for assistance in calculating safe and specific venting requirements for equipment.

Sprinkler

CAUTION

Sprinkler systems place a large quantity of water in the dust collector when activated. Provide adequate drainage to remove water. Excess water weight can cause the leg structure to collapse.

Optional fire control sprinklers are available for all models operating under negative pressure. Torit-supplied sprinklers require a minimum of 15-psig water pressure to each module. The volume of water discharged per sprinkler head is 17 gallons per minute.

NOTICE

Consult with local authorities when installing fire control systems on dust collection equipment.

1. Remove the top filter access doors and filters to access the sprinkler taps located inside the dirty-air plenum.
2. Apply pipe sealant to the threads of the pipe reducer located on the sprinkler assembly.
3. Thread sprinkler assembly onto the 1-in diameter sprinkler tap.
4. Tighten securely.

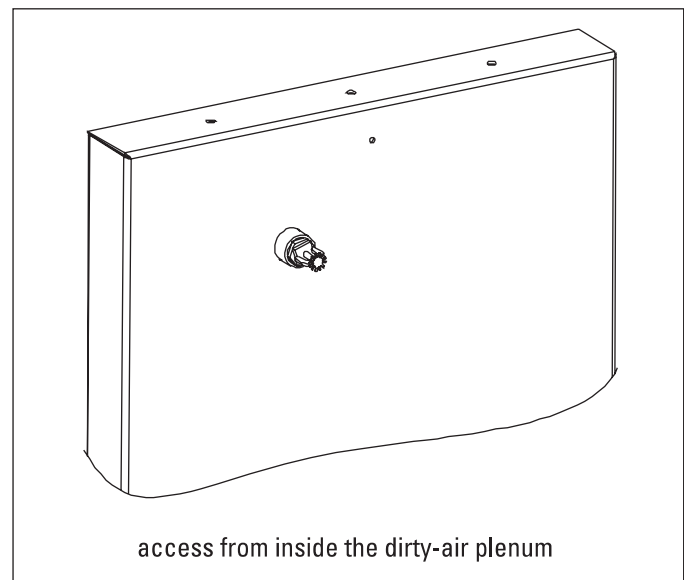

Sprinkler Installation

Troubleshooting

Problem	Probable Cause	Remedy
Power pack fan and motor do not start	Improper motor wire size	Rewire using the correct wire gauge as specified by national and local codes.
	Not wired correctly	Check and correct motor wiring for supply voltage. See motor manufacturer's wiring diagram. Follow wiring diagram and the National Electric Code.
	Unit not wired for available voltage	Correct wiring for proper supply voltage.
	Input circuit down	Check power supply to motor circuit on all leads.
	Electrical supply circuit down	Check power supply circuit for proper voltage. Check for fuse or circuit breaker fault. Replace as necessary.
Power pack fan and motor start, but do not stay running	Incorrect motor starter installed	Check for proper motor starter and replace if necessary.
	Access doors are open or not closed tight	Close and tighten access doors. See Filter Replacement.
	Hopper discharge open	Check that dust container is installed and properly sealed.
	Damper control not adjusted properly	Check airflow in duct. Adjust damper control until proper airflow is achieved and the blower motor's amp draw is within the manufacturer's rated amps.
	Electrical circuit overload	Check that the power supply circuit has sufficient power to run all equipment.
Clean-air outlet discharging dust	Filters not installed correctly	See Filter Installation.
	Filter damage, dents in the end caps, gasket damage, or holes in media	Replace filters as necessary. Use only genuine Donaldson replacement parts. See Filter Installation.
	Access cover(s) loose	Tighten access doors securely. See Filter Installation.
Insufficient airflow	Fan rotation backwards	Proper fan rotation is clockwise from the top of the unit. The fan can be viewed through the back of the motor. See Preliminary Start-Up Check.
	Access doors open or not closed tight	Check that all access doors are in place and secured. Check that the hopper discharge opening is sealed and that dust container is installed correctly.
	Fan exhaust area restricted	Check fan exhaust area for obstructions. Remove material or debris. Adjust damper flow control.
	Filters need replacement	Remove and replace using genuine Donaldson replacement filters. See Filter Removal and Installation.

Problem	Probable Cause	Remedy
Insufficient airflow continued	Lack of compressed air	See Rating and Specification Information for compressed air supply requirements.
	Pulse cleaning not energized	Use a voltmeter to check the solenoid valves in the control panel. Check pneumatic lines for kinks or obstructions.
	Dust storage area overfilled or plugged	Clean out dust storage area. See Dust Disposal.
	Pulse valves leaking compressed air	Lock out all electrical power to the unit and bleed the compressed air supply. Check for debris, valve wear, pneumatic tubing fault, or diaphragm failure by removing the diaphragm cover on the pulse valves. Check for solenoid leaks or damage. If pulse valves or solenoid valves and tubing are damaged, replace.
	Solid-State timer failure	Using a voltmeter, check supply voltage to the timer board. Check and replace the fuse on the timer board if necessary. If the fuse is good and input power is present but output voltage to the solenoid is not, replace the timer board. See Solid-State Timer Installation.
	Solid-State timer out of adjustment	See Solid-State Timer and Solid-State Timer Wiring Diagram.
No display on the Delta P Controller	No power to the controller	Use a voltmeter to check for supply voltage.
	Fuse blown	Check the fuse in the control panel. See wiring diagram inside the control panel. Replace if necessary.
Display on Delta P Controller does not read zero when at rest	Out of calibration	Recalibrate as described in Delta P Maintenance Manual.
	With collector discharging outside, differential pressure is present from indoor to outdoor	Recalibrate with the pressure tubing attached as described in the Delta P Maintenance Manual.
Delta P Controller ON, but cleaning system does not start	Pressure tubing disconnected, ruptured, or plugged	Check tubing for kinks, breaks, contamination, or loose connections.
	Not wired to the timing board correctly	Connect the pressure switch on the timer board to Terminals 7 and 8 on TB3.
	Faulty relay	Using a multimeter, test relay for proper closure. Replace if necessary.

Troubleshooting

Problem	Probable Cause	Remedy
Pulse cleaning never stops	Pressure switch not wired to the timer board correctly	Connect the pressure switch on the timer board to Terminals 7 and 8 on TB3.
	Pressure switch terminals on the timer board jumpered	Remove jumper wire on Solid-State Timer board before wiring to the Delta P Control.
	High Pressure On or Low Pressure Off setpoint not adjusted for system conditions	Adjust setpoints to current conditions.
	Pressure tubing disconnected, ruptured, plugged, or kinked	Check tubing for kinks, breaks, contamination, or loose connections.
Alarm light is ON	Alarm setpoint too low	Adjust to a higher value.
	Excess pressure drop	Check cleaning system and compressed air supply. Replace filters if filters do not clean down.
	Pressure tubing disconnected, ruptured, plugged, or kinked	Check tubing for kinks, breaks, contamination, or loose connections.
Delta P arrow keys to not work	Improper operation	Press and hold one of the three setpoint keys to use arrow keys.
	Programming keys disabled	Remove the Program Disable jumper from Terminals 3 and 4 on TB2.
Cleaning light is ON, but cleaning system not functioning	Improper wiring	Check wiring between the Delta P Control and the timer board, and between the timer board and solenoid valve coils.
	Defective solenoids	Check all solenoid coils for proper operation.
	Timer board not powered	Check power ON light on timer board's LED display. If not illuminated, check the supply voltage to the timer board. Check the fuse on the timer board. Replace if necessary.
	Timer board defective	If LED is illuminated, observe the output display. Install a temporary jumper across the pressure switch terminals. Output levels should flash in sequence. Check output using a multimeter set to 150-Volt AC range. Measure from SOL COM to a solenoid output. The needle will deflect when LED flashes for that output if voltage is present. If LED's do not flash, or if no voltage is present at output terminals during flash, replace the board.

The Donaldson Torit Warranty

Donaldson does not warrant against damages due to corrosion, abrasion, normal wear and tear, product modification, or product misapplication. Donaldson also makes no warranty whatsoever as to any goods manufactured or supplied by others including electric motors, fans and control components. After Donaldson has been given adequate opportunity to remedy any defects in material or workmanship, Donaldson retains the sole option to accept return of the goods, with freight paid by the purchaser, and to refund the purchase price for the goods after confirming the goods are returned undamaged and in usable condition. Such a refund will be in the full extent of Donaldson's liability. Donaldson shall not be liable for any other costs, expenses or damages whether direct, indirect, special, incidental, consequential or otherwise. The terms of this warranty may be modified only by a special warranty document signed by a Director, General Manager or Vice President of Donaldson. Failure to use genuine Donaldson replacement parts may void this warranty. THERE EXIST NO OTHER REPRESENTATIONS, WARRANTIES OR GUARANTEES EXCEPT AS STATED IN THIS PARAGRAPH AND ALL OTHER WARRANTIES INCLUDING MERCHANTABILITY AND FITNESS FOR A PARTICULAR PURPOSE, WHETHER EXPRESS OR IMPLIED ARE HEREBY EXPRESSLY EXCLUDED AND DISCLAIMED.



Parts and Service

For genuine Donaldson replacement filters and parts, call the Parts Express Line. For faster service, have unit's model and serial number, quantity, part number, and description available.

Donaldson Australasia
Tel: 1800 503 878 (AU)
Tel: 0800 743 387 (NZ)
Website: www.donaldsonfilters.com.au

Donaldson China
Tel: 400 820 1038
Website: www.donaldson.cn

Donaldson South Asia
Tel: +91 124 480 7536
Website: www.india.donaldson.com

Donaldson Japan
Tel: +81 42 540 4114
Website: www.donaldson.co.jp

Donaldson Korea
Tel: +82 251 733 33
Website: www.donaldson.co.kr

Donaldson Europe
Tel: +32 16 383 811
Website: www.donaldson.com

Donaldson Southeast Asia
Tel: +65 6349 8168
Website: www.asia.donaldson.com

Donaldson USA
Tel: +1 800 365 1331
Website: www.donaldson.com

Donaldson Company, Inc. is the leading designer and manufacturer of dust, mist, and fume collection equipment used to control industrial-air pollutants. Our equipment is designed to help reduce occupational hazards, lengthen machine life, reduce in-plant maintenance requirements, and improve product quality.